

Panasonic

High Speed Scanner

Operating Instructions

Model No. KV-S6040W / KV-S6045W /
KV-S6040WU / KV-S6045WU

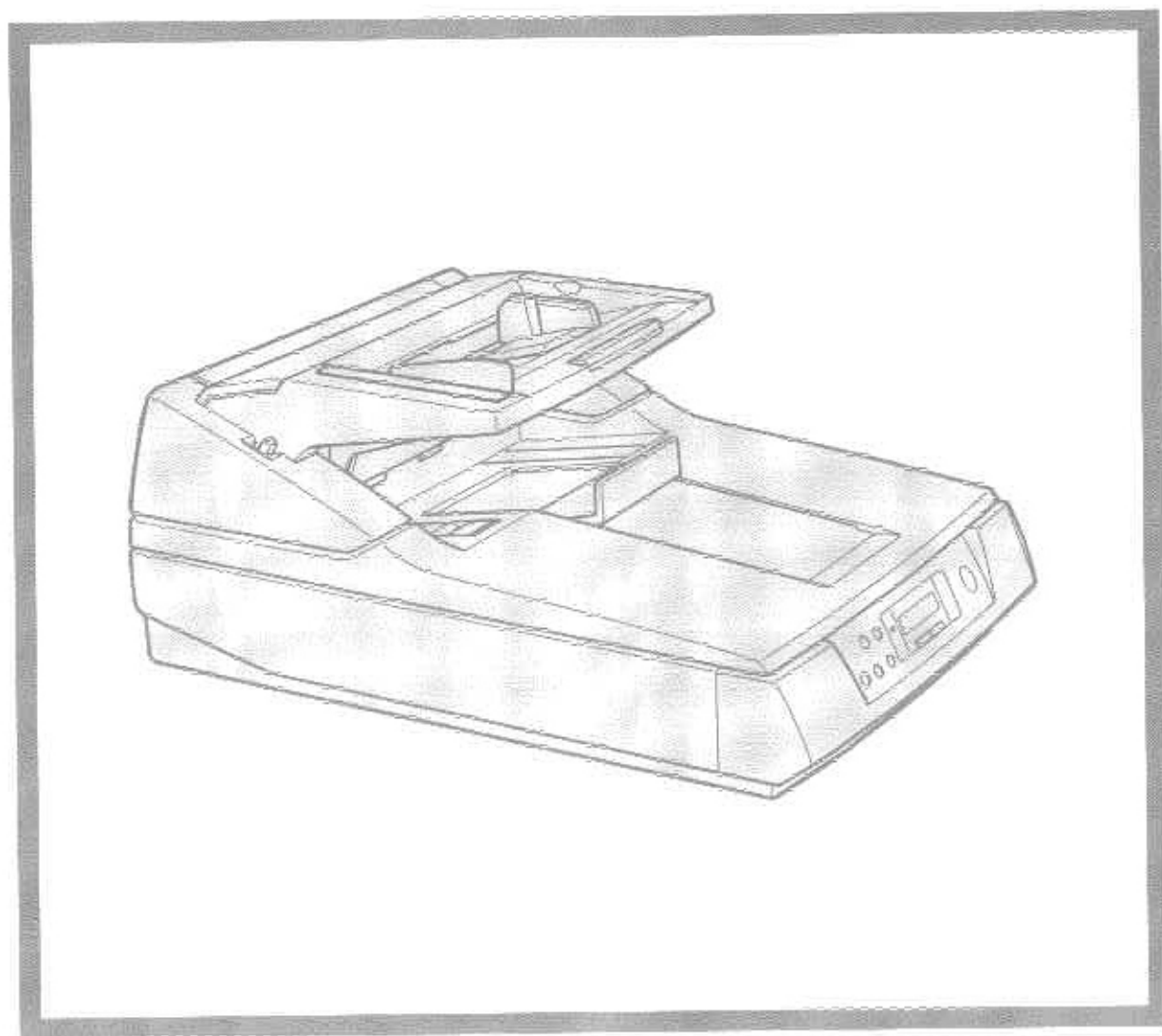

These instructions contain the information on operating the scanner. **Before reading these instructions, please read the installation manual that is enclosed with this unit.**

Please read all sections of these instructions, the enclosed installation manual and maintenance manual completely before using this product. Keep all documentation regarding this product in safe place for future reference.

Thank you for purchasing a Panasonic "High Speed Scanner".

■ Required Host System Conditions

When using the scanner, the required host computer conditions are as follows.

CPU	486 DX 66 MHz or higher (Pentium 166 MHz or higher is recommended.)
Memory	16 MB or higher (64 MB or higher is recommended.)
OS	Windows [®] 3.1 / Windows [®] 95 / Windows [®] 98 / Windows NT [®]
SCSI board	Adaptec Brand AHA-1540 Series / AHA-2940 Series are recommended.

※The scanning speed differs depending on the host computer operating environment or application.

- Windows[®] is Microsoft[®] Windows[®] operating system.
- Microsoft[®], Windows[®] and Windows NT[®] are registered trademarks of Microsoft Corporation in the United States and/or other countries.
- Each company's name or company product name is each company's trademark or registered trademark.

The information given in these Operating Instructions is subject to change without notice.
These Operating Instructions are printed on recycled paper.

Table of Contents

	Page
Notice	4
Precautions	7
Component Identification	9
Display Panel Instructions	11
● Display panel and keys	11
● Setting the scanner	12
Loading Documents on the ADF	25
Loading Documents on the Flatbed	28
● When scanning with the flatbed one time	28
● When scanning with the flatbed repeatedly	29
● Scanning thick documents	30
Feeding a Document Manually	31
Clearing Paper Jams	32
● Removing paper jams from the feed part	32
● Removing paper jams from the exit part	33
Cleaning the Unit	34
● Outside of the scanner	34
● Inside the scanner	34
● Cleaning the rollers	34
● Cleaning the scanning section glass, CIS glass, white plate, white sensor roller, document sensors, double feed detection sensors and paper detection sensor	37
● Document glass and cover sheet	41
● Roller cleaning paper	41
Replacing Consumable Roller Modules	42
Repacking Instructions	48
Specifications	49
Troubleshooting	51
Index	54

※German display on the display panel is described on pages 14 through 24 and 52 to 53, and German contents to be selected are described on pages 15 through 23.

Notice

Federal Communications Commission Requirements

(For United States only)

Note: This equipment has been tested and found to comply with the limits for a Class A digital device, pursuant to part 15 of the FCC Rules. These limits are designed to provide reasonable protection against harmful interference when the equipment is operated in a commercial environment. This equipment generates, uses, and can radiate radio frequency energy and, if not installed and used in accordance with the instruction manual, may cause harmful interference to radio communications. Operation of this equipment in a residential area is likely to cause harmful interference in which case the user will be required to correct the interference at his own expense.

FCC Warning: To assure continued FCC compliance, the user must use only shielded interface cable and the provided power supply cord. Also, any unauthorized changes or modifications to this equipment would void the user's authority to operate this device.

English

WARNING:

TO PREVENT FIRE OR SHOCK HAZARD, DO NOT EXPOSE THIS PRODUCT TO RAIN OR ANY TYPE OF MOISTURE.

THE SOCKET-OUTLET MUST BE NEAR THIS EQUIPMENT AND MUST BE EASILY ACCESSIBLE.

Français

Avertissement:

Pour éviter tout risque d'incendie ou de choc électrique, ne pas soumettre cet appareil à la pluie ou à l'humidité.

"La prise secteur devra se trouver à proximité de l'appareil et être facilement accessible."

Deutsch

Warnung:

Zur Verhütung von Feuer dem und elektrischem Schlag dieses Erzeugnis nicht Regen oder sonstiger Feuchtigkeit aussetzen.



Die Steckdose muß nahe bei diesem Gerät angebracht und leicht zugänglich sein.

Für Benutzer in der BRD

Hinweis:

Der arbeitsplatzbezogene Geräuschemissionswert dieses Gerätes beträgt ≤ 70 dB(A) nach DIN 45635 Teil 19.

For your safety please read the following text carefully.**(For United Kingdom only)**

This appliance is supplied with a moulded three pin mains plug for your safety and convenience. A 5 amp. fuse is fitted in this plug. Should the fuse need to be replaced please ensure that the replacement fuse has a rating of 5 amps. and that it is approved by ASTA or BSI to BS1362. Check for the ASTA mark  or the BSI mark  on the body of the fuse. If the plug contains a removable fuse cover you must ensure that it is refitted when the fuse is replaced. If you lose the fuse cover the plug must not be used until a replacement cover is obtained. A replacement fuse cover can be purchased from your local Panasonic Dealer.

If the fitted moulded plug is unsuitable for the socket outlet in your home then the fuse should be removed and the plug cut off and disposed of safely.

There is danger of severe electrical shock if the cut off plug is inserted into any 13 amp. socket.

If a new plug is to be fitted please observe the wiring code as shown below. If in any doubt please consult a qualified electrician.

WARNING : This appliance must be earthed.

IMPORTANT : The wires in this mains lead are coloured in accordance with the following code.

Green-and-Yellow	: Earth
Blue	: Neutral
Brown	: Live

As the colours of the wire in the mains lead of this appliance may not correspond with the coloured markings identifying the terminals in your plug, proceed as follows.

The wire which is coloured Green-and-Yellow must be connected to the terminal in the plug which is marked with the letter E or by the Earth symbol \perp or coloured Green-and-Yellow.

The wire which is coloured Blue must be connected to the terminal in the plug which is marked with the letter N or coloured Black.

The wire which is coloured Brown must be connected to the terminal in the plug which is marked with the letter L or coloured Red.

How to replace the fuse :

Open the fuse compartment with a screwdriver and replace the fuse.

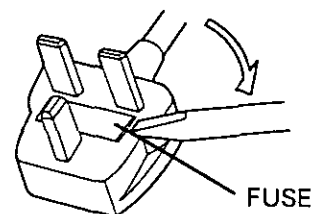
**English**

The product should be used only with a power cord that is supplied by the manufacturer.

Français

Le produit ne devra être utilisé qu'avec le cordon d'alimentation fourni par le fabricant.

Deutsch

Dieses Gerät darf nur mit dem vom Hersteller gelieferten Netzkabel verwendet werden.

警告使用者

這是甲類的資訊產品，在居住的環境中使用時，可能會造成射頻干擾，在這種情況下，使用者會被要求採取某些適當的對策。

Notice

For roller cleaning paper

Before using the roller cleaning paper, please read these instructions completely. Keep these instructions for future reference.

English

WARNING

- Do not drink or inhale the roller cleaning paper fluid as it contains isopropyl alcohol.
- The roller cleaning paper may be harmful to sensitive skin, so please use protective gloves.
- Do not use the roller cleaning paper near a heater or open flame.
- Do not store the roller cleaning paper in direct sunlight or in a place over 40 °C (104 °F).
- Only use the roller cleaning paper to clean the rollers and scanning area.
- If you need more information about the roller cleaning paper, please refer to the Material Safety Data Sheet (MSDS).
- Please ask your Panasonic sales company about obtaining the Material Safety Data Sheet.

KEEP THIS CLEANING PAPER AWAY FROM FIRE.

Français

Avertissement

- Ne pas absorber le liquide du papier de nettoyage de rouleaux fourni ni en respirer les émanations car il contient de l'alcool isopropylique.
- Le papier de nettoyage de rouleaux pouvant être néfaste pour les peaux sensibles, utiliser des gants de protection.
- Ne pas utiliser le papier de nettoyage de rouleaux à proximité d'un feu ou d'une flamme vive.
- Ne pas ranger le papier de nettoyage de rouleaux en plein soleil ni à une température dépassant 40 °C (104 °F).
- Utiliser le papier de nettoyage de rouleaux exclusivement pour le nettoyage des rouleaux et de la surface de balayage.
- Pour tout renseignement complémentaire sur le papier de nettoyage de rouleaux, voir la feuille de données sur la sécurité du matériel.
- Pour la feuille de données sur la sécurité du matériel, s'adresser au revendeur Panasonic.

NE PAS APPROCHER DU FEU.

Deutsch

WARNUNG

- Die Walzenreinigungspapier-Reinigungsflüssigkeit enthält Isopropylalkohol und darf auf keinen Fall getrunken oder inhaliert werden.
- Bitte Schutzhandschuhe tragen, da das Walzenreinigungspapier bei empfindlicher Haut Reizungen verursachen kann.
- Das Walzenreinigungspapier nicht in der Nähe von Heizgeräten oder offenen Flammen verwenden.
- Das Walzenreinigungspapier nicht in direkter Sonneneinstrahlung oder an Orten lagern, an denen Temperaturen von mehr als 40 °C erreicht werden.
- Zum Reinigen der Walzen und des Scanbereichs ausschließlich das Walzenreinigungspapier verwenden.
- Weitere Informationen zum Walzenreinigungspapier sind dem Materialsicherheits-Datenblatt zu entnehmen.
- Das Materialsicherheits-Datenblatt ist auf Wunsch von Ihrem Panasonic-Fachhändler erhältlich.

VON FEUER FERNHALTEN!

Caution for copying

- Do not duplicate bills, coins, securities and the like (with this system).
- Do not duplicate copyrighted material or the work of others except for the purpose of private use.
- Do not duplicate any kind of certificates, licenses, passports, official or private documents, and the like.

Precautions

The following precautions are recommended to extend the life of the unit.

Do not place any liquids near the unit.
— Accidental spillage of liquid into the unit may cause severe damage. If this occurs, turn the unit off, unplug the power cord and call for service.

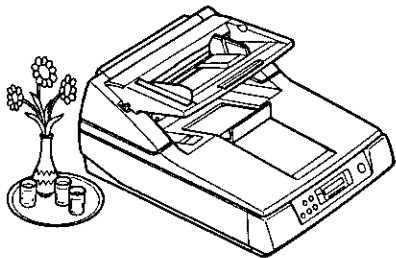

Do not place books, paper, or other items on the unit.

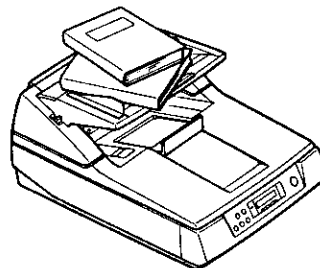

Do not place the unit in an area where there is a lot of smoke, dust, chemical fumes or vibration.

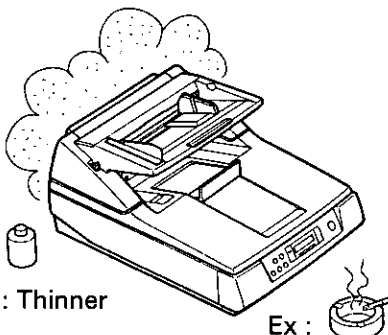

Do not leave the power cord plugged into the AC outlet if the unit is not used for an extended period.

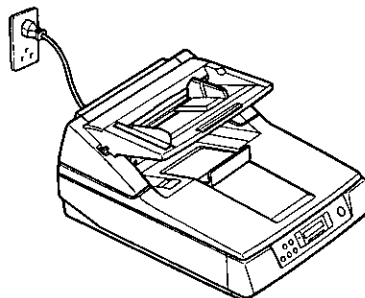

Do not place the unit on an uneven or unstable surface.

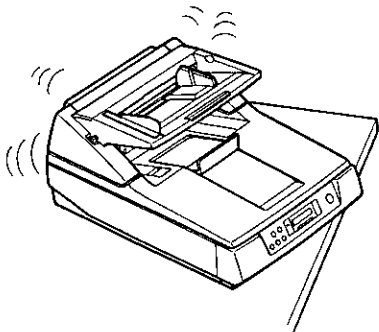

Do not disassemble this unit. This will void the warranty.

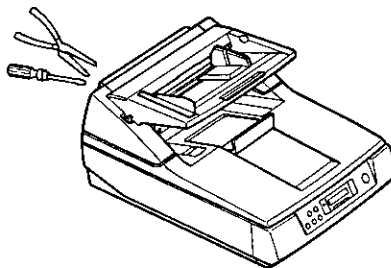

It is recommended that if the scanner has to be moved, at least two people carry it.

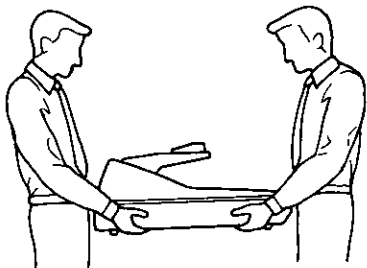

Do not look directly at the light.
(You may damage your eyes.)

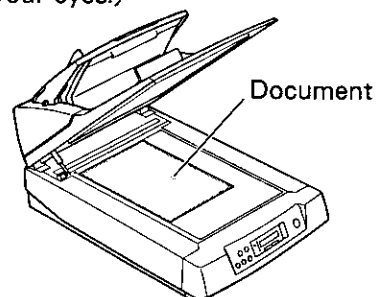

● Special care should be taken to protect the unit if it is used in a less than optimum environment, such as a dusty or sandy area.

Precautions

Operating Environment

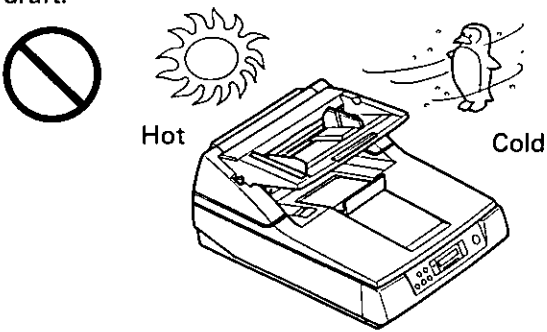
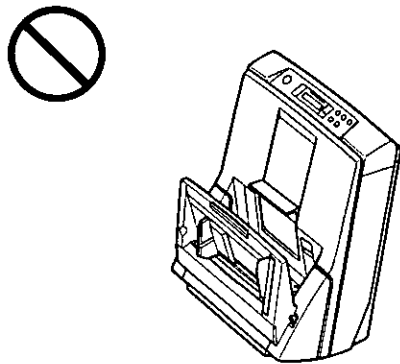
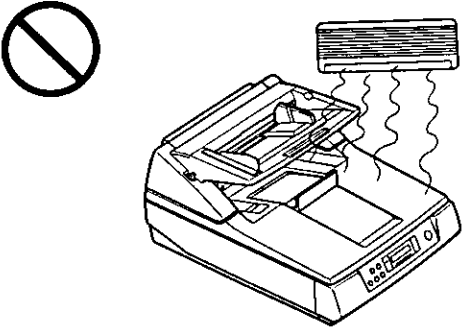
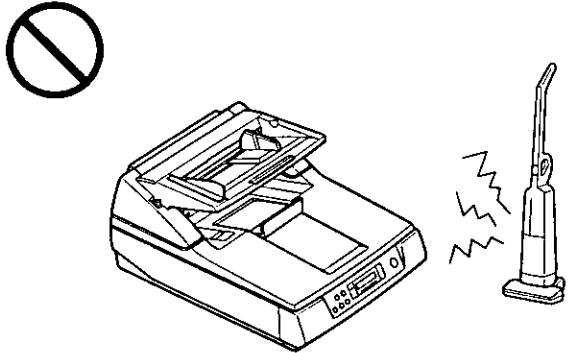
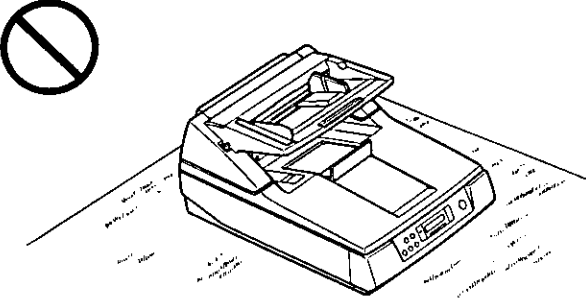
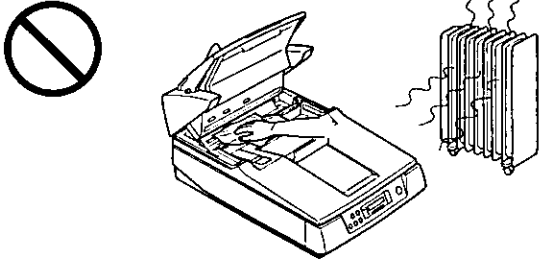
<p>Do not place the unit in direct sunlight or in a cold draft.</p>  <p>Hot Cold</p>	<p>Do not operate or place the unit in a vertical position.</p> 
<p>Do not place the unit near a heating appliance or an air conditioning vent. Do not place the unit in a room with extremely high or low humidity.</p> 	<p>Do not place the unit near other appliances which generate large electrical noise.</p> 
<p>Do not place the unit on a carpet. (Static electricity can cause the unit to malfunction.)</p> 	<p>Do not drink or inhale the included roller cleaning paper fluid. The roller cleaning paper may be harmful to sensitive skin, so please use protective gloves. Do not use the roller cleaning paper near a heater or open flame. This may cause a fire.</p> 

● Power Source

- Use a voltage level that does not vary more than $\pm 10\%$ from the voltage level marked on the nameplate (located on the back side of the scanner).
- Do not use an extension cord.
- This scanner should be connected to a grounded outlet.
- Do not use a line conditioner, transient suppressor or surge protector.

Component Identification

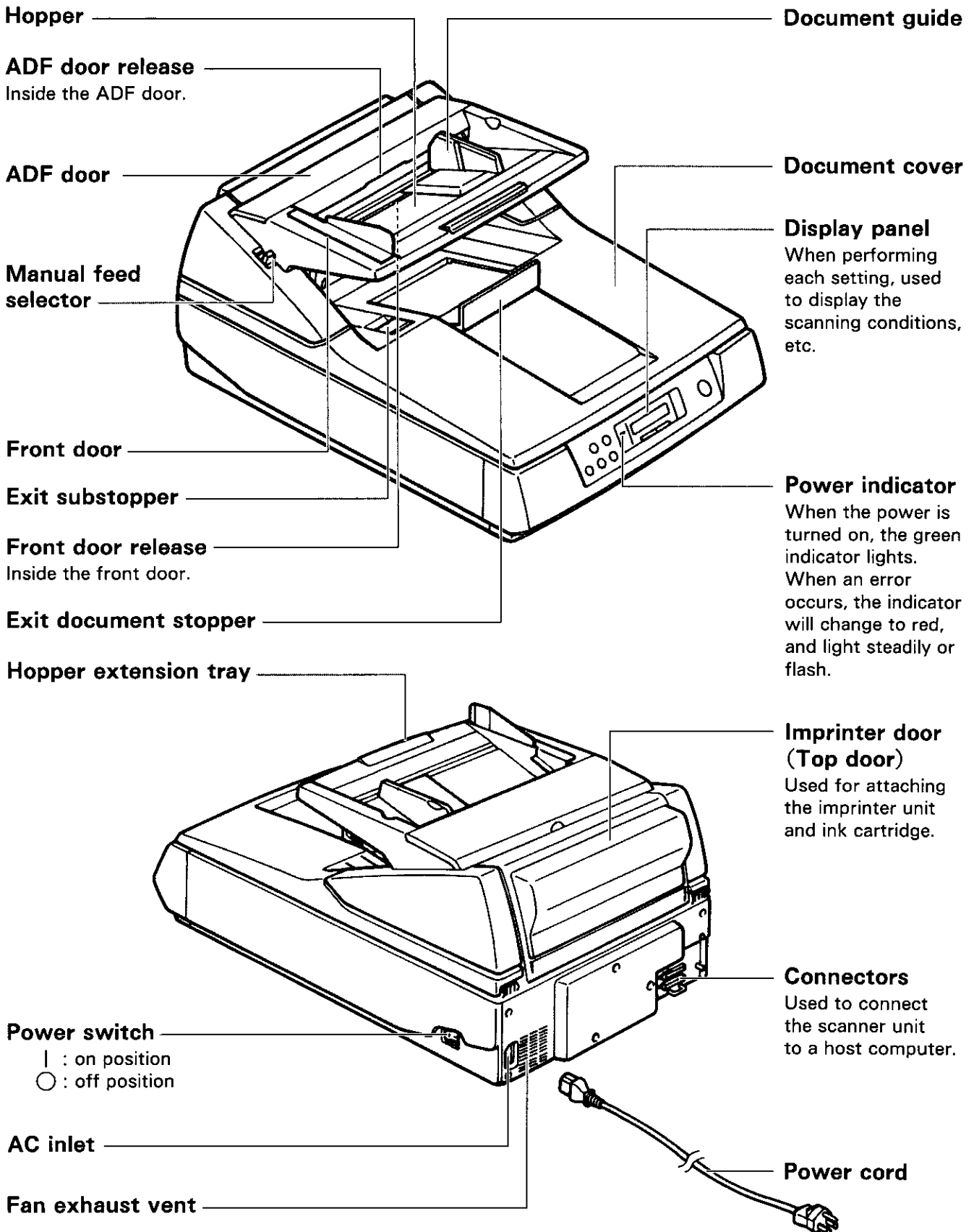

Component Identification

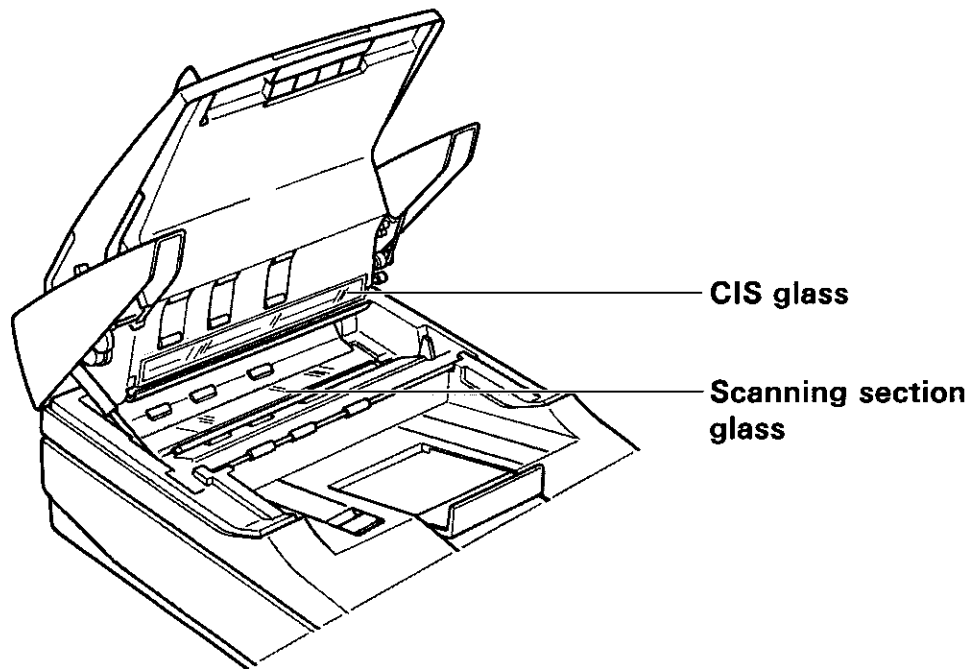
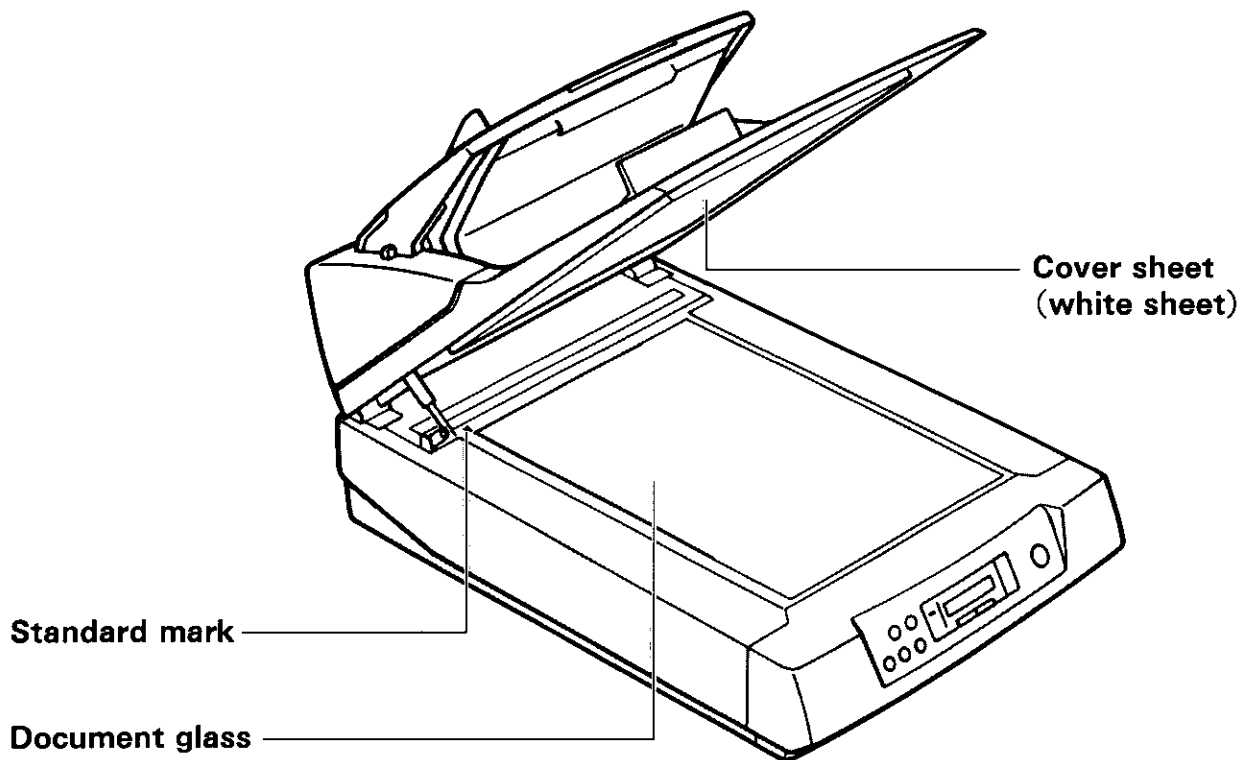

Display Panel Instructions

■ Setting the scanner

The following parameters can be customized using the scanner's various setting modes. If the application software provides these features, it will be supported by the scanner.

Scan menu

Item	Contents
Front side brightness	Selection for density when scanning the front side of a document.
Front side image emphasis	Selection for emphasis when scanning the front side of a document.
Front side contrast	Selection for contrast when scanning the front side of a document.
Front side halftone	Selection for gradation when scanning the front side of a document.
Back side brightness (For KV-S6045W series only)	Selection for density when scanning the back side of a document.
Back side image emphasis (For KV-S6045W series only)	Selection for emphasis when scanning the back side of a document.
Back side contrast (For KV-S6045W series only)	Selection for contrast when scanning the back side of a document.
Back side halftone (For KV-S6045W series only)	Selection for gradation when scanning the back side of a document.
Noise reduction	Selection for noise reduction when scanning a document.
Double feed detection	Selection to detect double feeding function. When scanning very important documents, confirm if the number of scanned pages displayed on the LCD matches the number of actual pages.
Feed speed	Selection for feed speed when a document is being scanned.
Black line removal	Selection to remove the black lines which appear at the top and bottom of the image after scanning the document.
Scanning mode	Selects whether documents are scanned at actual size or reduced (Fit to Page) side.
Scanning method	Selection of documents to be scanned. This includes documents placed in the ADF and documents placed on the flatbed glass (document glass).
Save "Scanning Settings" (Select memory)	Selects the memory where the conditions are saved.
Save "Scanning Settings" (Execution)	Saves the scanning conditions into the memory. (2 memory settings)
Load scanning setting	Loads the memory where the scanning conditions have already been saved. If "Default" is selected, all of the scanning conditions will return to the default values.

Counter menu

Item	Contents
Select the counter displayed on the LCD	Selection to display the cleared counter (scan counter) after scanning one time or to display the user set counter (user counter) on the LCD.
Setting the user counter	Selection for default number before scanning.
Setting the "User Counter Extender"	Selection for an increase number of extender in the default number.
Clear the "User Counter"	Clears the counter which was set by the user.

Imprinter menu

Depending on the setting of the "Counter setting menu", the page number of the scanned document will be printed. The imprinter unit (KV-SS010) is required. If a host computer is connected, there may be settings required on the host computer as well.

Item	Contents
Setting the imprinter data	Allows for the printing data to be selected. The imprinter will print on the front side of the document scanned.
Setting the imprinter position	Allows for the selection of the printing position using a imprinter.

"Others" menu

Item	Contents
Checking the Firmware Version	Displays the firmware version of the mechanical control or imprinter. If an optional imprinter is not installed, the imprinter version will not be displayed.
Setting the "Buzzer"	Selects whether the buzzer is turned on or off. If selection is in the "ON" position : When pressing a key, one short beep will be heard. When there is an error, five short beeps will be heard. When scanning is completed, one long beep will be heard.
Setting the SCSI ID	Sets the SCSI ID number.
Setting the "Terminator"	Sets "Enable" or "Disable".
Checking the "Roller Cleaning Warning"	The alarm tells you it is time to check the roller. If it is near 100%, clean the roller. See "Cleaning the Unit" on page 34.
Clearing the "Roller Cleaning Warning"	Clear the "Clean Roller Warning ○○%" display.
Checking the roller modules replacement warning	The alarm tells you the roller modules need to be changed. If it is near 100%, replace the paper feed roller module, separation roller module and retard roller module. See "Replacing Consumable Roller Modules" on page 42.
Clearing the roller modules replacement warning	Clear the "Replace Roll. Warning ○○%" display.
Setting the "Product ID"	Selects the product ID. The product ID setting depends on the host computer scanner application you are using.
Setting the "Double Feed" detector sensitivity	Selects the sensitivity of the Double Feed Detector.
Setting the "Detect Skew"	Selects whether skew is detected or not detected.

Display Panel Instructions

● Operation

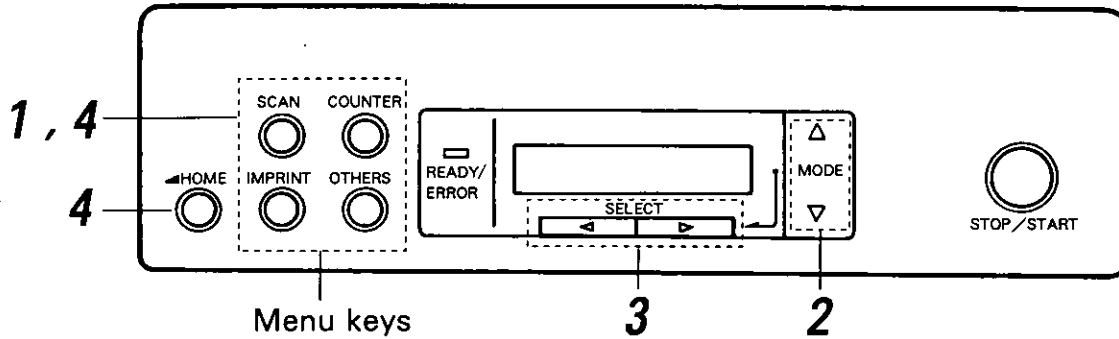

1 Press the menu key until the desired menu is displayed.

- The **SCAN**, **COUNTER**, **IMPRINT** and **OTHERS** keys are used as menu keys.
- When pressing the **SCAN** key, the display will appear as shown in the diagram on the right.

0	1	.	F	.	B	r	i	g	h	t	n	e	s	s	
D	-	-	-	-	+	-	-	-	-	L	H	o	s	t	

0	1	.	H	e	l	l	i	g	k	.	V	o	r	n	
D	-	-	-	-	+	-	-	-	-	H	H	o	s	t	

2 Use the ▲ key or the ▼ key to select the desired item.

- The display at the right is an example of a setting for the scanning setting mode.

0	7	.	B	.	C	o	n	t	r	a	s	t		
L	-	-	-	-	+	-	-	-	-	H	H	o	s	t

0	7	.	K	o	n	t	r	.	h	i	n	t	.	
N	-	-	-	-	+	-	-	-	-	H	H	o	s	t

3 Use the ► key or the ◀ key to select the desired content.

- The display on the right is an example of a setting for the back side contrast. It will be displayed as "B. Contrast".

0	7	.	B	.	C	o	n	t	r	a	s	t		
L	-	-	*	-	+	-	-	-	-	H			L	2

0	7	.	K	o	n	t	r	.	h	i	n	t	.	
N	-	-	*	-	+	-	-	-	-	H			N	2

4 Press the HOME key to return to the "Ready" display or another menu key to go to another menu.

When the HOME key is pressed :

R	e	a	d	y										
B	e	r	e	i	t									

When the COUNTER key is pressed for another menu key :

0	1	.	D	i	s	p	.	C	o	u	n	t	e	r		
													S	c	a	n

0	1	.	Z	a	e	h	l	e	r	a	n	z	.			
													S	c	a	n

※In steps 2 or 3, you can change to the desired menu by pressing the desired menu key.

※ See pages 15 to 23 for details.

※ For changing the display language, see page 24.

※ Upper display of each step is in English and lower one is in German.

● Actual settings Scan setting menu (by pressing the SCAN key)

Number, mode and default display <ul style="list-style-type: none"> ● Pressing the ▲ key will change to the next mode. ● Pressing the ▼ key will change to the previous mode. 	Contents <ul style="list-style-type: none"> ● Pressing the ► key or the ◀ key will change to another value. 																																																																				
01 Front side brightness <table border="1" style="width: 100%; border-collapse: collapse;"> <tr><td>0</td><td>1</td><td>.</td><td>F</td><td>.</td><td>B</td><td>r</td><td>i</td><td>g</td><td>h</td><td>t</td><td>n</td><td>e</td><td>s</td><td>s</td><td></td><td></td></tr> <tr><td>D</td><td>-</td><td>-</td><td>-</td><td>-</td><td>+</td><td>-</td><td>-</td><td>-</td><td>-</td><td>L</td><td>H</td><td>o</td><td>s</td><td>t</td><td></td><td></td></tr> </table> <table border="1" style="width: 100%; border-collapse: collapse;"> <tr><td>0</td><td>1</td><td>.</td><td>H</td><td>e</td><td>l</td><td>l</td><td>i</td><td>g</td><td>k</td><td>.</td><td>v</td><td>o</td><td>r</td><td>n</td><td></td><td></td></tr> <tr><td>D</td><td>-</td><td>-</td><td>-</td><td>-</td><td>+</td><td>-</td><td>-</td><td>-</td><td>-</td><td>H</td><td>H</td><td>o</td><td>s</td><td>t</td><td></td><td></td></tr> </table>	0	1	.	F	.	B	r	i	g	h	t	n	e	s	s			D	-	-	-	-	+	-	-	-	-	L	H	o	s	t			0	1	.	H	e	l	l	i	g	k	.	v	o	r	n			D	-	-	-	-	+	-	-	-	-	H	H	o	s	t			<div style="text-align: center;"> <p>D4 ↔ D3 ↔ D2 ↔ D1 ↔ Norm ↔ L1 ↔ L2 ↔ L3 ↔ L4</p> <p>↑</p> <p>Host ←</p> </div> <div style="text-align: center;"> <p>D4 ↔ D3 ↔ D2 ↔ D1 ↔ Norm ↔ H1 ↔ H2 ↔ H3 ↔ H4</p> <p>↑</p> <p>Host ←</p> </div> <ul style="list-style-type: none"> ● When "Host" is displayed, pressing the ► key or the ◀ key will change the display to "Norm". ● "D" means dark. "L" means light.
0	1	.	F	.	B	r	i	g	h	t	n	e	s	s																																																							
D	-	-	-	-	+	-	-	-	-	L	H	o	s	t																																																							
0	1	.	H	e	l	l	i	g	k	.	v	o	r	n																																																							
D	-	-	-	-	+	-	-	-	-	H	H	o	s	t																																																							
02 Front side image emphasis <table border="1" style="width: 100%; border-collapse: collapse;"> <tr><td>0</td><td>2</td><td>.</td><td>F</td><td>.</td><td>E</td><td>m</td><td>p</td><td>h</td><td>a</td><td>s</td><td>i</td><td>s</td><td></td><td></td><td></td><td></td></tr> <tr><td></td><td></td><td></td><td>-</td><td>-</td><td>-</td><td>+</td><td>-</td><td></td><td></td><td></td><td></td><td></td><td>H</td><td>o</td><td>s</td><td>t</td></tr> </table> <table border="1" style="width: 100%; border-collapse: collapse;"> <tr><td>0</td><td>2</td><td>.</td><td>H</td><td>e</td><td>r</td><td>v</td><td>o</td><td>r</td><td>h</td><td>.</td><td>v</td><td>o</td><td>r</td><td>n</td><td></td><td></td></tr> <tr><td></td><td></td><td></td><td>-</td><td>-</td><td>-</td><td>+</td><td>-</td><td></td><td></td><td></td><td></td><td></td><td>H</td><td>o</td><td>s</td><td>t</td></tr> </table>	0	2	.	F	.	E	m	p	h	a	s	i	s								-	-	-	+	-						H	o	s	t	0	2	.	H	e	r	v	o	r	h	.	v	o	r	n						-	-	-	+	-						H	o	s	t	<div style="text-align: center;"> <p>Smooth ↔ None ↔ Low ↔ Medium ↔ High</p> <p>↑</p> <p>Host ←</p> </div> <div style="text-align: center;"> <p>Gleichm ↔ Keine ↔ Niedrig ↔ Mittel ↔ Hoch</p> <p>↑</p> <p>Host ←</p> </div> <ul style="list-style-type: none"> ● When "Host" is displayed, pressing the ► key or the ◀ key will change the display to "Medium".
0	2	.	F	.	E	m	p	h	a	s	i	s																																																									
			-	-	-	+	-						H	o	s	t																																																					
0	2	.	H	e	r	v	o	r	h	.	v	o	r	n																																																							
			-	-	-	+	-						H	o	s	t																																																					
03 Front side contrast <table border="1" style="width: 100%; border-collapse: collapse;"> <tr><td>0</td><td>3</td><td>.</td><td>F</td><td>.</td><td>C</td><td>o</td><td>n</td><td>t</td><td>r</td><td>a</td><td>s</td><td>t</td><td></td><td></td><td></td><td></td></tr> <tr><td>L</td><td>-</td><td>-</td><td>-</td><td>-</td><td>+</td><td>-</td><td>-</td><td>-</td><td>-</td><td>H</td><td>H</td><td>o</td><td>s</td><td>t</td><td></td><td></td></tr> </table> <table border="1" style="width: 100%; border-collapse: collapse;"> <tr><td>0</td><td>3</td><td>.</td><td>K</td><td>o</td><td>n</td><td>t</td><td>r</td><td>.</td><td>v</td><td>o</td><td>r</td><td>n</td><td></td><td></td><td></td><td></td></tr> <tr><td>N</td><td>-</td><td>-</td><td>-</td><td>-</td><td>+</td><td>-</td><td>-</td><td>-</td><td>-</td><td>H</td><td>H</td><td>o</td><td>s</td><td>t</td><td></td><td></td></tr> </table>	0	3	.	F	.	C	o	n	t	r	a	s	t					L	-	-	-	-	+	-	-	-	-	H	H	o	s	t			0	3	.	K	o	n	t	r	.	v	o	r	n					N	-	-	-	-	+	-	-	-	-	H	H	o	s	t			<div style="text-align: center;"> <p>L4 ↔ L3 ↔ L2 ↔ L1 ↔ Norm ↔ H1 ↔ H2 ↔ H3 ↔ H4</p> <p>↑</p> <p>Host ←</p> </div> <div style="text-align: center;"> <p>N4 ↔ N3 ↔ N2 ↔ N1 ↔ Norm ↔ H1 ↔ H2 ↔ H3 ↔ H4</p> <p>↑</p> <p>Host ←</p> </div> <ul style="list-style-type: none"> ● When "Host" is displayed, pressing the ► key or the ◀ key will change the display to "Norm". ● "H" means high. "L" means low.
0	3	.	F	.	C	o	n	t	r	a	s	t																																																									
L	-	-	-	-	+	-	-	-	-	H	H	o	s	t																																																							
0	3	.	K	o	n	t	r	.	v	o	r	n																																																									
N	-	-	-	-	+	-	-	-	-	H	H	o	s	t																																																							

- For changing the display language, see page 24.
- Upper display and chart in each cell is in English and lower one is in German.

Display Panel Instructions

<p>04 Front side halftone</p> <table border="1" data-bbox="181 349 668 414"> <tr><td>0</td><td>4</td><td>.</td><td>F</td><td>.</td><td>H</td><td>a</td><td>l</td><td>f</td><td>t</td><td>o</td><td>n</td><td>e</td><td></td><td></td></tr> <tr><td></td><td></td><td></td><td></td><td></td><td></td><td></td><td></td><td></td><td></td><td></td><td></td><td></td><td>H</td><td>o</td><td>s</td><td>t</td></tr> </table> <table border="1" data-bbox="181 445 668 511"> <tr><td>0</td><td>4</td><td>.</td><td>H</td><td>a</td><td>l</td><td>b</td><td>i</td><td>t</td><td>o</td><td>n</td><td></td><td>v</td><td>o</td><td>r</td><td>n</td><td></td></tr> <tr><td></td><td></td><td></td><td></td><td></td><td></td><td></td><td></td><td></td><td></td><td></td><td></td><td></td><td>H</td><td>o</td><td>s</td><td>t</td></tr> </table>	0	4	.	F	.	H	a	l	f	t	o	n	e																H	o	s	t	0	4	.	H	a	l	b	i	t	o	n		v	o	r	n															H	o	s	t	<p>→ Host ↔ Binary ↔ Bayer dither 64 ↔ Bayer dither 16 ←</p> <p>↳ Halftone dot 32 ↔ Halftone dot 64 ↔ Error diffusion ←</p> <p>→ Host ↔ Binaer ↔ Bayer Dither 64 ↔ Bayer Dither 16 ←</p> <p>↳ Halbton Punkt 32 ↔ Halbton Punkt 64 ←</p> <p>↳ Fehlerdiffusion ←</p>				
0	4	.	F	.	H	a	l	f	t	o	n	e																																																											
													H	o	s	t																																																							
0	4	.	H	a	l	b	i	t	o	n		v	o	r	n																																																								
													H	o	s	t																																																							
<p>05 Back side brightness</p> <table border="1" data-bbox="181 660 668 725"> <tr><td>0</td><td>5</td><td>.</td><td>B</td><td>.</td><td>B</td><td>r</td><td>i</td><td>g</td><td>h</td><td>t</td><td>n</td><td>e</td><td>s</td><td>s</td><td></td></tr> <tr><td>D</td><td>-</td><td>-</td><td>-</td><td>-</td><td>+</td><td>-</td><td>-</td><td>-</td><td>-</td><td>L</td><td></td><td></td><td></td><td>H</td><td>o</td><td>s</td><td>t</td></tr> </table> <table border="1" data-bbox="181 756 668 821"> <tr><td>0</td><td>5</td><td>.</td><td>H</td><td>e</td><td>l</td><td>l</td><td>i</td><td>g</td><td>k</td><td>.</td><td>h</td><td>i</td><td>n</td><td>t</td><td>.</td><td></td></tr> <tr><td>D</td><td>-</td><td>-</td><td>-</td><td>-</td><td>+</td><td>-</td><td>-</td><td>-</td><td>-</td><td>H</td><td></td><td></td><td></td><td></td><td>H</td><td>o</td><td>s</td><td>t</td></tr> </table> <ul style="list-style-type: none"> ● KV-S6045W series only. 	0	5	.	B	.	B	r	i	g	h	t	n	e	s	s		D	-	-	-	-	+	-	-	-	-	L				H	o	s	t	0	5	.	H	e	l	l	i	g	k	.	h	i	n	t	.		D	-	-	-	-	+	-	-	-	-	H					H	o	s	t	<p>D4 ↔ D3 ↔ D2 ↔ D1 ↔ Norm ↔ L1 ↔ L2 ↔ L3 ↔ L4</p> <p>↑</p> <p>→ Host ←</p> <p>D4 ↔ D3 ↔ D2 ↔ D1 ↔ Norm ↔ H1 ↔ H2 ↔ H3 ↔ H4</p> <p>↑</p> <p>→ Host ←</p> <ul style="list-style-type: none"> ● When "Host" is displayed, pressing the ► key or the ◀ key will change the display to "Norm". ● "D" means dark. "L" means light.
0	5	.	B	.	B	r	i	g	h	t	n	e	s	s																																																									
D	-	-	-	-	+	-	-	-	-	L				H	o	s	t																																																						
0	5	.	H	e	l	l	i	g	k	.	h	i	n	t	.																																																								
D	-	-	-	-	+	-	-	-	-	H					H	o	s	t																																																					
<p>06 Back side image emphasis</p> <table border="1" data-bbox="181 1073 668 1138"> <tr><td>0</td><td>6</td><td>.</td><td>B</td><td>.</td><td>E</td><td>m</td><td>p</td><td>h</td><td>a</td><td>s</td><td>i</td><td>s</td><td></td><td></td></tr> <tr><td></td><td></td><td></td><td>-</td><td>-</td><td>-</td><td>+</td><td>-</td><td></td><td></td><td></td><td></td><td></td><td>H</td><td>o</td><td>s</td><td>t</td></tr> </table> <table border="1" data-bbox="181 1169 668 1234"> <tr><td>0</td><td>6</td><td>.</td><td>H</td><td>e</td><td>r</td><td>v</td><td>o</td><td>r</td><td>h</td><td>.</td><td>h</td><td>i</td><td>n</td><td>t</td><td>.</td><td></td></tr> <tr><td></td><td></td><td></td><td>-</td><td>-</td><td>-</td><td>+</td><td>-</td><td></td><td></td><td></td><td></td><td></td><td>H</td><td>o</td><td>s</td><td>t</td></tr> </table> <ul style="list-style-type: none"> ● KV-S6045W series only. 	0	6	.	B	.	E	m	p	h	a	s	i	s						-	-	-	+	-						H	o	s	t	0	6	.	H	e	r	v	o	r	h	.	h	i	n	t	.					-	-	-	+	-						H	o	s	t	<p>Smooth ↔ None ↔ Low ↔ Medium ↔ High</p> <p>↑</p> <p>→ Host ←</p> <p>Gleichm ↔ Keine ↔ Niedrig ↔ Mittel ↔ Hoch</p> <p>↑</p> <p>→ Host ←</p> <ul style="list-style-type: none"> ● When "Host" is displayed, pressing the ► key or the ◀ key will change the display to "Medium". 				
0	6	.	B	.	E	m	p	h	a	s	i	s																																																											
			-	-	-	+	-						H	o	s	t																																																							
0	6	.	H	e	r	v	o	r	h	.	h	i	n	t	.																																																								
			-	-	-	+	-						H	o	s	t																																																							
<p>07 Back side contrast</p> <table border="1" data-bbox="181 1426 668 1492"> <tr><td>0</td><td>7</td><td>.</td><td>B</td><td>.</td><td>C</td><td>o</td><td>n</td><td>t</td><td>r</td><td>a</td><td>s</td><td>t</td><td></td><td></td></tr> <tr><td>L</td><td>-</td><td>-</td><td>-</td><td>-</td><td>+</td><td>-</td><td>-</td><td>-</td><td>-</td><td>H</td><td></td><td></td><td></td><td>H</td><td>o</td><td>s</td><td>t</td></tr> </table> <table border="1" data-bbox="181 1522 668 1588"> <tr><td>0</td><td>7</td><td>.</td><td>K</td><td>o</td><td>n</td><td>t</td><td>r</td><td>.</td><td></td><td>h</td><td>i</td><td>n</td><td>t</td><td>.</td><td></td></tr> <tr><td>N</td><td>-</td><td>-</td><td>-</td><td>-</td><td>+</td><td>-</td><td>-</td><td>-</td><td>-</td><td>H</td><td></td><td></td><td></td><td>H</td><td>o</td><td>s</td><td>t</td></tr> </table> <ul style="list-style-type: none"> ● KV-S6045W series only. 	0	7	.	B	.	C	o	n	t	r	a	s	t			L	-	-	-	-	+	-	-	-	-	H				H	o	s	t	0	7	.	K	o	n	t	r	.		h	i	n	t	.		N	-	-	-	-	+	-	-	-	-	H				H	o	s	t	<p>L4 ↔ L3 ↔ L2 ↔ L1 ↔ Norm ↔ H1 ↔ H2 ↔ H3 ↔ H4</p> <p>↑</p> <p>→ Host ←</p> <p>N4 ↔ N3 ↔ N2 ↔ N1 ↔ Norm ↔ H1 ↔ H2 ↔ H3 ↔ H4</p> <p>↑</p> <p>→ Host ←</p> <ul style="list-style-type: none"> ● When "Host" is displayed, pressing the ► key or the ◀ key will change the display to "Norm". ● "H" means high. "L" means low. 			
0	7	.	B	.	C	o	n	t	r	a	s	t																																																											
L	-	-	-	-	+	-	-	-	-	H				H	o	s	t																																																						
0	7	.	K	o	n	t	r	.		h	i	n	t	.																																																									
N	-	-	-	-	+	-	-	-	-	H				H	o	s	t																																																						

<p>08 Back side halftone</p> <table border="1"> <tr><td>0</td><td>8</td><td>.</td><td>B</td><td>.</td><td>H</td><td>a</td><td>l</td><td>f</td><td>t</td><td>o</td><td>n</td><td>e</td><td>.</td><td>.</td><td>.</td></tr> <tr><td></td><td></td><td></td><td></td><td></td><td></td><td></td><td></td><td></td><td></td><td></td><td></td><td></td><td></td><td>H</td><td>o</td><td>s</td><td>t</td></tr> </table> <table border="1"> <tr><td>0</td><td>8</td><td>.</td><td>H</td><td>a</td><td>l</td><td>b</td><td>t</td><td>o</td><td>n</td><td>h</td><td>i</td><td>n</td><td>t</td><td>.</td><td>.</td><td>.</td></tr> <tr><td></td><td></td><td></td><td></td><td></td><td></td><td></td><td></td><td></td><td></td><td></td><td></td><td></td><td></td><td>H</td><td>o</td><td>s</td><td>t</td></tr> </table> <p>● KV-S6045W series only.</p>	0	8	.	B	.	H	a	l	f	t	o	n	e	.	.	.															H	o	s	t	0	8	.	H	a	l	b	t	o	n	h	i	n	t	.	.	.															H	o	s	t	<p>→ Host ↔ Binary ↔ Bayer dither 64 ↔ Bayer dither 16 ←</p> <p>→ Halftone dot 32 ↔ Halftone dot 64 ↔ Error diffusion ←</p> <p>→ Host ↔ Binaer ↔ Bayer Dither 64 ↔ Bayer Dither 16 ←</p> <p>→ Halbton Punkt 32 ↔ Halbton Punkt 64 ←</p> <p>→ Fehlerdiffusion ←</p>		
0	8	.	B	.	H	a	l	f	t	o	n	e	.	.	.																																																									
														H	o	s	t																																																							
0	8	.	H	a	l	b	t	o	n	h	i	n	t	.	.	.																																																								
														H	o	s	t																																																							
<p>09 Noise reduction</p> <table border="1"> <tr><td>0</td><td>9</td><td>.</td><td>N</td><td>o</td><td>i</td><td>s</td><td>e</td><td></td><td>R</td><td>e</td><td>d</td><td>u</td><td>c</td><td>t</td><td>.</td><td>.</td><td>.</td></tr> <tr><td></td><td></td><td></td><td>+</td><td>-</td><td>-</td><td>-</td><td>-</td><td>-</td><td></td><td></td><td></td><td></td><td></td><td>H</td><td>o</td><td>s</td><td>t</td></tr> </table> <table border="1"> <tr><td>0</td><td>9</td><td>.</td><td>S</td><td>t</td><td>ö</td><td>r</td><td>r</td><td>e</td><td>d</td><td>.</td><td>.</td><td>.</td><td>.</td><td>.</td><td>.</td></tr> <tr><td></td><td></td><td></td><td>+</td><td>-</td><td>-</td><td>-</td><td>-</td><td>-</td><td></td><td></td><td></td><td></td><td></td><td>H</td><td>o</td><td>s</td><td>t</td></tr> </table>	0	9	.	N	o	i	s	e		R	e	d	u	c	t	.	.	.				+	-	-	-	-	-						H	o	s	t	0	9	.	S	t	ö	r	r	e	d				+	-	-	-	-	-						H	o	s	t	<p>→ Host ↔ None ↔ 1×1 ↔ 2×2 ←</p> <p>→ 3×3 ↔ 4×4 ↔ 5×5 ↔ 6×6 ←</p> <p>→ Host ↔ Ohne ↔ 1×1 ↔ 2×2 ←</p> <p>→ 3×3 ↔ 4×4 ↔ 5×5 ↔ 6×6 ←</p>	
0	9	.	N	o	i	s	e		R	e	d	u	c	t	.	.	.																																																							
			+	-	-	-	-	-						H	o	s	t																																																							
0	9	.	S	t	ö	r	r	e	d																																																									
			+	-	-	-	-	-						H	o	s	t																																																							
<p>10 Double feed detection</p> <table border="1"> <tr><td>1</td><td>0</td><td>.</td><td>D</td><td>o</td><td>u</td><td>b</td><td>l</td><td>e</td><td></td><td>F</td><td>e</td><td>e</td><td>d</td><td>.</td><td>.</td><td>.</td></tr> <tr><td></td><td></td><td></td><td></td><td></td><td></td><td></td><td></td><td></td><td></td><td></td><td></td><td></td><td></td><td>H</td><td>o</td><td>s</td><td>t</td></tr> </table> <table border="1"> <tr><td>1</td><td>0</td><td>.</td><td>D</td><td>o</td><td>p</td><td>p</td><td>e</td><td>l</td><td>e</td><td>i</td><td>n</td><td>z</td><td>u</td><td>g</td><td>.</td><td>.</td><td>.</td></tr> <tr><td></td><td></td><td></td><td></td><td></td><td></td><td></td><td></td><td></td><td></td><td></td><td></td><td></td><td></td><td>H</td><td>o</td><td>s</td><td>t</td></tr> </table>	1	0	.	D	o	u	b	l	e		F	e	e	d	.	.	.															H	o	s	t	1	0	.	D	o	p	p	e	l	e	i	n	z	u	g	.	.	.															H	o	s	t	<p>→ Host ↔ Not detect ↔ Detect ←</p> <p>→ Host ↔ Nicht erkennen ↔ Erkennen ←</p> <p>If set to "Detect", the scanner will sound a buzzer and the power indicator will flash red when double feeding is detected. Even if this buzzer is set to "OFF" in "Setting the Buzzer" (see page 21), it will still ring.</p> <p>● When scanning very important documents, confirm if the number of scanned pages displayed on the LCD matches the number of actual pages.</p>
1	0	.	D	o	u	b	l	e		F	e	e	d	.	.	.																																																								
														H	o	s	t																																																							
1	0	.	D	o	p	p	e	l	e	i	n	z	u	g	.	.	.																																																							
														H	o	s	t																																																							
<p>11 Feed speed</p> <table border="1"> <tr><td>1</td><td>1</td><td>.</td><td>F</td><td>e</td><td>e</td><td>d</td><td></td><td>S</td><td>p</td><td>e</td><td>e</td><td>d</td><td>.</td><td>.</td><td>.</td></tr> <tr><td></td><td></td><td></td><td></td><td></td><td></td><td></td><td></td><td></td><td></td><td></td><td></td><td></td><td></td><td>H</td><td>o</td><td>s</td><td>t</td></tr> </table> <table border="1"> <tr><td>1</td><td>1</td><td>.</td><td>G</td><td>e</td><td>s</td><td>c</td><td>h</td><td>w</td><td>.</td><td>E</td><td>i</td><td>n</td><td>z</td><td>u</td><td>g</td><td>.</td><td>.</td><td>.</td></tr> <tr><td></td><td></td><td></td><td></td><td></td><td></td><td></td><td></td><td></td><td></td><td></td><td></td><td></td><td></td><td>H</td><td>o</td><td>s</td><td>t</td></tr> </table>	1	1	.	F	e	e	d		S	p	e	e	d	.	.	.															H	o	s	t	1	1	.	G	e	s	c	h	w	.	E	i	n	z	u	g	.	.	.															H	o	s	t	<p>→ Host ↔ Slow ↔ Normal ←</p> <p>→ Host ↔ Langsam ↔ Normal ←</p>
1	1	.	F	e	e	d		S	p	e	e	d	.	.	.																																																									
														H	o	s	t																																																							
1	1	.	G	e	s	c	h	w	.	E	i	n	z	u	g	.	.	.																																																						
														H	o	s	t																																																							
<p>12 Black line removal</p> <table border="1"> <tr><td>1</td><td>2</td><td>.</td><td>B</td><td>L</td><td>K</td><td></td><td>L</td><td>i</td><td>n</td><td>e</td><td>.</td><td>.</td><td>.</td></tr> <tr><td></td><td></td><td></td><td>R</td><td>e</td><td>m</td><td>o</td><td>v</td><td>e</td><td></td><td></td><td></td><td></td><td>H</td><td>o</td><td>s</td><td>t</td></tr> </table> <table border="1"> <tr><td>1</td><td>2</td><td>.</td><td>S</td><td>t</td><td>r</td><td>i</td><td>c</td><td>h</td><td>l</td><td>ö</td><td>s</td><td>c</td><td>h</td><td>e</td><td>n</td><td>.</td><td>.</td><td>.</td></tr> <tr><td></td><td></td><td></td><td>L</td><td>ö</td><td>s</td><td>c</td><td>h</td><td>e</td><td>n</td><td></td><td></td><td></td><td></td><td>H</td><td>o</td><td>s</td><td>t</td></tr> </table>	1	2	.	B	L	K		L	i	n	e	.	.	.				R	e	m	o	v	e					H	o	s	t	1	2	.	S	t	r	i	c	h	l	ö	s	c	h	e	n	.	.	.				L	ö	s	c	h	e	n					H	o	s	t	<p>→ Host ↔ Disable ↔ Enable ←</p> <p>→ Host ↔ Aus ↔ Ein ←</p>			
1	2	.	B	L	K		L	i	n	e	.	.	.																																																											
			R	e	m	o	v	e					H	o	s	t																																																								
1	2	.	S	t	r	i	c	h	l	ö	s	c	h	e	n	.	.	.																																																						
			L	ö	s	c	h	e	n					H	o	s	t																																																							
<p>13 Scanning mode</p> <table border="1"> <tr><td>1</td><td>3</td><td>.</td><td>S</td><td>c</td><td>a</td><td>n</td><td>n</td><td>i</td><td>n</td><td>g</td><td></td><td>M</td><td>o</td><td>d</td><td>e</td><td>.</td><td>.</td><td>.</td></tr> <tr><td></td><td></td><td></td><td></td><td></td><td></td><td></td><td></td><td></td><td></td><td></td><td></td><td></td><td></td><td>H</td><td>o</td><td>s</td><td>t</td></tr> </table> <table border="1"> <tr><td>1</td><td>3</td><td>.</td><td>S</td><td>c</td><td>a</td><td>n</td><td></td><td>M</td><td>o</td><td>d</td><td>u</td><td>s</td><td>.</td><td>.</td><td>.</td></tr> <tr><td></td><td></td><td></td><td></td><td></td><td></td><td></td><td></td><td></td><td></td><td></td><td></td><td></td><td></td><td>H</td><td>o</td><td>s</td><td>t</td></tr> </table>	1	3	.	S	c	a	n	n	i	n	g		M	o	d	e	.	.	.															H	o	s	t	1	3	.	S	c	a	n		M	o	d	u	s	.	.	.															H	o	s	t	<p>→ Host ↔ Fit to Page ↔ Actual ←</p> <p>→ Host ↔ Seitenanpassung ↔ Aktuell ←</p> <p>Fit to Page : Scanner shrinks image to fit scanned page. Actual : Scanner scans at 100% actual page size. Some of the data on the edges of the page may be lost.</p>
1	3	.	S	c	a	n	n	i	n	g		M	o	d	e	.	.	.																																																						
														H	o	s	t																																																							
1	3	.	S	c	a	n		M	o	d	u	s	.	.	.																																																									
														H	o	s	t																																																							

Display Panel Instructions

<p>14 Scanning method</p> <table border="1"> <tr><td>1</td><td>4</td><td>.</td><td>S</td><td>c</td><td>a</td><td>n</td><td>M</td><td>e</td><td>t</td><td>h</td><td>o</td><td>d</td><td></td></tr> <tr><td></td><td></td><td></td><td></td><td></td><td></td><td></td><td></td><td></td><td></td><td></td><td></td><td>H</td><td>o</td><td>s</td><td>t</td></tr> </table> <table border="1"> <tr><td>1</td><td>4</td><td>.</td><td>A</td><td>b</td><td>t</td><td>a</td><td>s</td><td>t</td><td>u</td><td>n</td><td>g</td><td></td><td></td></tr> <tr><td></td><td></td><td></td><td></td><td></td><td></td><td></td><td></td><td></td><td></td><td></td><td></td><td>H</td><td>o</td><td>s</td><td>t</td></tr> </table>	1	4	.	S	c	a	n	M	e	t	h	o	d														H	o	s	t	1	4	.	A	b	t	a	s	t	u	n	g															H	o	s	t	<p>→ Host ↔ FB ←</p> <p>→ Host ↔ Flachbett ←</p> <p>Host: The documents placed either on the ADF or on the flatbed are scanned in response to commands from the host computer.</p> <p>FB: The documents placed on the flatbed are scanned.</p>											
1	4	.	S	c	a	n	M	e	t	h	o	d																																																												
												H	o	s	t																																																									
1	4	.	A	b	t	a	s	t	u	n	g																																																													
												H	o	s	t																																																									
<p>15 Save "Scanning Settings" (Select memory)</p> <table border="1"> <tr><td>1</td><td>5</td><td>.</td><td>S</td><td>a</td><td>v</td><td>e</td><td>S</td><td>e</td><td>t</td><td>t</td><td>i</td><td>n</td><td>g</td><td></td></tr> <tr><td></td><td></td><td></td><td></td><td></td><td></td><td></td><td></td><td></td><td></td><td></td><td></td><td>M</td><td>e</td><td>m</td><td>o</td><td>r</td><td>y</td><td>1</td></tr> </table> <table border="1"> <tr><td>1</td><td>5</td><td>.</td><td>E</td><td>i</td><td>n</td><td>s</td><td>t</td><td>e</td><td>l</td><td>l</td><td>.</td><td>s</td><td>i</td><td>c</td><td>h</td></tr> <tr><td></td><td></td><td></td><td></td><td></td><td></td><td></td><td></td><td></td><td></td><td></td><td></td><td>S</td><td>p</td><td>e</td><td>i</td><td>c</td><td>h</td><td>e</td><td>r</td><td>1</td></tr> </table>	1	5	.	S	a	v	e	S	e	t	t	i	n	g														M	e	m	o	r	y	1	1	5	.	E	i	n	s	t	e	l	l	.	s	i	c	h													S	p	e	i	c	h	e	r	1	<p>→ Memory 1 ↔ Memory 2 ←</p> <p>→ Speicher 1 ↔ Speicher 2 ←</p>
1	5	.	S	a	v	e	S	e	t	t	i	n	g																																																											
												M	e	m	o	r	y	1																																																						
1	5	.	E	i	n	s	t	e	l	l	.	s	i	c	h																																																									
												S	p	e	i	c	h	e	r	1																																																				
<p>15 Save "Scanning Settings" (Execution)</p> <table border="1"> <tr><td>1</td><td>5</td><td>.</td><td>S</td><td>a</td><td>v</td><td>e</td><td>S</td><td>e</td><td>t</td><td>t</td><td>i</td><td>n</td><td>g</td><td></td></tr> <tr><td></td><td></td><td></td><td></td><td></td><td></td><td></td><td></td><td></td><td></td><td></td><td></td><td>E</td><td>x</td><td>e</td><td>c</td><td>=</td><td><</td><td>></td></tr> </table> <table border="1"> <tr><td>1</td><td>5</td><td>.</td><td>E</td><td>i</td><td>n</td><td>s</td><td>t</td><td>e</td><td>l</td><td>l</td><td>.</td><td>s</td><td>i</td><td>c</td><td>h</td></tr> <tr><td></td><td></td><td></td><td></td><td></td><td></td><td></td><td></td><td></td><td></td><td></td><td></td><td>A</td><td>u</td><td>s</td><td>f</td><td>.</td><td>=</td><td><</td><td>></td></tr> </table>	1	5	.	S	a	v	e	S	e	t	t	i	n	g														E	x	e	c	=	<	>	1	5	.	E	i	n	s	t	e	l	l	.	s	i	c	h													A	u	s	f	.	=	<	>	<p>When pressing the ► key and the ◀ key simultaneously, the scanning conditions set in 01 to 14 above will be saved in the memory selected in the "Save Scanning Settings (Select memory)".</p> <p>"Completed" will be displayed after saving.</p>	
1	5	.	S	a	v	e	S	e	t	t	i	n	g																																																											
												E	x	e	c	=	<	>																																																						
1	5	.	E	i	n	s	t	e	l	l	.	s	i	c	h																																																									
												A	u	s	f	.	=	<	>																																																					
<p>16 Load scanning setting</p> <table border="1"> <tr><td>1</td><td>6</td><td>.</td><td>L</td><td>o</td><td>a</td><td>d</td><td>S</td><td>e</td><td>t</td><td>t</td><td>i</td><td>n</td><td>g</td><td></td></tr> <tr><td></td><td></td><td></td><td></td><td></td><td></td><td></td><td></td><td></td><td></td><td></td><td></td><td>D</td><td>e</td><td>f</td><td>a</td><td>u</td><td>l</td><td>t</td></tr> </table> <table border="1"> <tr><td>1</td><td>6</td><td>.</td><td>E</td><td>i</td><td>n</td><td>s</td><td>t</td><td>e</td><td>l</td><td>l</td><td>.</td><td>l</td><td>a</td><td>d</td><td>.</td></tr> <tr><td>V</td><td>o</td><td>r</td><td>e</td><td>i</td><td>n</td><td>s</td><td>t</td><td>e</td><td>l</td><td>l</td><td>u</td><td>n</td><td>g</td><td>e</td><td>n</td></tr> </table>	1	6	.	L	o	a	d	S	e	t	t	i	n	g														D	e	f	a	u	l	t	1	6	.	E	i	n	s	t	e	l	l	.	l	a	d	.	V	o	r	e	i	n	s	t	e	l	l	u	n	g	e	n	<p>→ Default ↔ Memory 1 ↔ Memory 2 ←</p> <p>→ Voreinstellungen ↔ Speicher 1 ↔ Speicher 2 ←</p> <ul style="list-style-type: none"> ● If you use the ► key or the ◀ key to select Memory 1 or Memory 2, the saved scanning items will become valid by the "Save Scanning Settings (Execution)". If other scanning items have been saved in another memory, during scanning you can change the scanning items easily. ● This setting will not be changed even if the power is turned off and on, and will remain valid. ● If "Default" is selected, all of the saved scanning settings will return to the default values. (See "01" to "14" of the left side display.) 					
1	6	.	L	o	a	d	S	e	t	t	i	n	g																																																											
												D	e	f	a	u	l	t																																																						
1	6	.	E	i	n	s	t	e	l	l	.	l	a	d	.																																																									
V	o	r	e	i	n	s	t	e	l	l	u	n	g	e	n																																																									

- Scanning settings 01-14 must be saved using setting "15 Save Scanning Settings (Execution)". Even if they are not saved, they will be applied. If the power is turned off, the next time the unit is used they will not be applied.

Display Panel Instructions

Imprinter setting menu (by pressing the IMPRINT key)

These setting can be done only when a imprinter unit is installed.

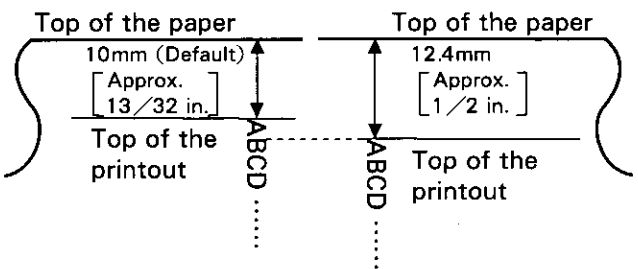
Number, item and default display	Contents																																																																																																
<p>● Pressing the ▲ key will change to the next mode.</p> <p>● Pressing the ▼ key will change to the previous mode.</p> <p>01 Setting the imprinter data</p> <table border="1" data-bbox="175 629 659 692"> <tr><td>0</td><td>1</td><td>.</td><td>P</td><td>r</td><td>e</td><td></td><td>I</td><td>m</td><td>p</td><td>r</td><td>i</td><td>n</td><td>t</td><td></td></tr> <tr><td></td><td></td><td></td><td></td><td></td><td></td><td></td><td></td><td></td><td></td><td></td><td></td><td>H</td><td>o</td><td>s</td><td>t</td></tr> </table> <table border="1" data-bbox="175 725 659 787"> <tr><td>0</td><td>1</td><td>.</td><td>D</td><td>r</td><td>u</td><td>c</td><td>k</td><td>e</td><td>r</td><td></td><td>v</td><td>o</td><td>r</td><td></td></tr> <tr><td></td><td></td><td></td><td></td><td></td><td></td><td></td><td></td><td></td><td></td><td></td><td></td><td>H</td><td>o</td><td>s</td><td>t</td></tr> </table> <p>● This setting can be done only when a imprinter is installed.</p>	0	1	.	P	r	e		I	m	p	r	i	n	t														H	o	s	t	0	1	.	D	r	u	c	k	e	r		v	o	r														H	o	s	t	<p>● Pressing the ► key or the ◀ key will change to another value.</p> <p>→Host ↔ Count←</p> <p>→Host ↔ Zähler←</p> <p>Host : Printing will be done according to the host computer. Count : Printing will be done according to the counter in the "Select the counter displayed on the LCD".</p>																																		
0	1	.	P	r	e		I	m	p	r	i	n	t																																																																																				
												H	o	s	t																																																																																		
0	1	.	D	r	u	c	k	e	r		v	o	r																																																																																				
												H	o	s	t																																																																																		
<p>02 Setting the imprinter position</p> <table border="1" data-bbox="175 932 659 994"> <tr><td>0</td><td>2</td><td>.</td><td>P</td><td>r</td><td>e</td><td></td><td>P</td><td>o</td><td>s</td><td>i</td><td>t</td><td>i</td><td>o</td><td>n</td><td></td></tr> <tr><td><</td><td></td><td>0</td><td>C</td><td>h</td><td>a</td><td>r</td><td>></td><td></td><td></td><td>1</td><td>0</td><td>.</td><td>0</td><td>m</td><td>m</td></tr> </table> <table border="1" data-bbox="175 1036 659 1098"> <tr><td>0</td><td>2</td><td>.</td><td>D</td><td>r</td><td>u</td><td>c</td><td>k</td><td>p</td><td>o</td><td>s</td><td>.</td><td></td><td>v</td><td>o</td><td>r</td></tr> <tr><td><</td><td></td><td>0</td><td>Z</td><td>e</td><td>i</td><td>c</td><td>h</td><td>></td><td></td><td>1</td><td>0</td><td>.</td><td>0</td><td>m</td><td>m</td></tr> </table> <p>● This setting can be done only when a imprinter is installed.</p>	0	2	.	P	r	e		P	o	s	i	t	i	o	n		<		0	C	h	a	r	>			1	0	.	0	m	m	0	2	.	D	r	u	c	k	p	o	s	.		v	o	r	<		0	Z	e	i	c	h	>		1	0	.	0	m	m	<p>By pressing the ► key or the ◀ key, you can specify the line where printing starts from the top of the document. If "0" character is set, printing starts from 10.0 mm. The millimeter value displayed is an approximation.</p> <table border="1" data-bbox="751 1056 1361 1129"> <tr><td>0</td><td>2</td><td>.</td><td>P</td><td>r</td><td>e</td><td></td><td>P</td><td>o</td><td>s</td><td>i</td><td>t</td><td>i</td><td>o</td><td>n</td><td></td></tr> <tr><td><</td><td></td><td>1</td><td>C</td><td>h</td><td>a</td><td>r</td><td>></td><td></td><td></td><td>1</td><td>2</td><td>.</td><td>4</td><td>m</td><td>m</td></tr> </table> <p>● In this example, printing starts at 12.4 mm (approx, 1/2 in.) from the top of the paper. The number 12.4 can be changed from 10.0 to 182.8 by pressing the ► key or the ◀ key.</p> 	0	2	.	P	r	e		P	o	s	i	t	i	o	n		<		1	C	h	a	r	>			1	2	.	4	m	m
0	2	.	P	r	e		P	o	s	i	t	i	o	n																																																																																			
<		0	C	h	a	r	>			1	0	.	0	m	m																																																																																		
0	2	.	D	r	u	c	k	p	o	s	.		v	o	r																																																																																		
<		0	Z	e	i	c	h	>		1	0	.	0	m	m																																																																																		
0	2	.	P	r	e		P	o	s	i	t	i	o	n																																																																																			
<		1	C	h	a	r	>			1	2	.	4	m	m																																																																																		

"Others" setting menu (by pressing the OTHERS key)

Number, mode and default display	Contents																																																																														
<ul style="list-style-type: none"> ● Pressing the ▲ key will change to the next mode. ● Pressing the ▼ key will change to the previous mode. 	<ul style="list-style-type: none"> ● Pressing the ► key or the ◀ key will change to another value. 																																																																														
01 Checking the Firmware Version <table border="1" style="width: 100%; border-collapse: collapse;"> <tr><td>0</td><td>1</td><td>.</td><td>V</td><td>e</td><td>r</td><td>s</td><td>i</td><td>o</td><td>n</td><td></td><td></td><td></td><td></td><td></td><td></td></tr> <tr><td></td><td></td><td></td><td>M</td><td>x</td><td>.</td><td>x</td><td>x</td><td>F</td><td>x</td><td>.</td><td>x</td><td>x</td><td></td><td></td><td></td></tr> </table> <table border="1" style="width: 100%; border-collapse: collapse;"> <tr><td>0</td><td>1</td><td>.</td><td>V</td><td>e</td><td>r</td><td>s</td><td>i</td><td>o</td><td>n</td><td></td><td></td><td></td><td></td><td></td><td></td></tr> <tr><td></td><td></td><td></td><td>M</td><td>x</td><td>.</td><td>x</td><td>x</td><td>F</td><td>x</td><td>.</td><td>x</td><td>x</td><td></td><td></td><td></td></tr> </table>	0	1	.	V	e	r	s	i	o	n										M	x	.	x	x	F	x	.	x	x				0	1	.	V	e	r	s	i	o	n										M	x	.	x	x	F	x	.	x	x				<p>Mx.xx : Displays the mechanical control firmware version.</p> <p>Fx.xx : Displays the imprinter firmware version. If a imprinter unit is not installed, the firmware version will not be displayed.</p>														
0	1	.	V	e	r	s	i	o	n																																																																						
			M	x	.	x	x	F	x	.	x	x																																																																			
0	1	.	V	e	r	s	i	o	n																																																																						
			M	x	.	x	x	F	x	.	x	x																																																																			
02 Setting the "Buzzer" <table border="1" style="width: 100%; border-collapse: collapse;"> <tr><td>0</td><td>2</td><td>.</td><td>B</td><td>u</td><td>z</td><td>z</td><td>e</td><td>r</td><td></td><td></td><td></td><td></td><td></td><td></td><td></td></tr> <tr><td></td><td></td><td></td><td></td><td></td><td></td><td></td><td></td><td></td><td></td><td></td><td></td><td></td><td></td><td>O</td><td>N</td></tr> </table> <table border="1" style="width: 100%; border-collapse: collapse;"> <tr><td>0</td><td>2</td><td>.</td><td>S</td><td>u</td><td>m</td><td>m</td><td>e</td><td>r</td><td>s</td><td>i</td><td>g</td><td>n</td><td>a</td><td>l</td><td></td></tr> <tr><td></td><td></td><td></td><td></td><td></td><td></td><td></td><td></td><td></td><td></td><td></td><td></td><td></td><td></td><td>E</td><td>i</td><td>n</td></tr> </table>	0	2	.	B	u	z	z	e	r																						O	N	0	2	.	S	u	m	m	e	r	s	i	g	n	a	l																E	i	n	<p>→ON ↔ OFF←</p> <p>→Ein ↔ Aus←</p>													
0	2	.	B	u	z	z	e	r																																																																							
														O	N																																																																
0	2	.	S	u	m	m	e	r	s	i	g	n	a	l																																																																	
														E	i	n																																																															
03 Setting the SCSI ID <table border="1" style="width: 100%; border-collapse: collapse;"> <tr><td>0</td><td>3</td><td>.</td><td>S</td><td>C</td><td>S</td><td>I</td><td></td><td>I</td><td>D</td><td></td><td></td><td></td><td></td><td></td><td></td></tr> <tr><td></td><td></td><td></td><td></td><td></td><td></td><td></td><td></td><td></td><td></td><td></td><td></td><td></td><td></td><td>N</td><td>o</td><td>.</td><td>0</td></tr> </table> <table border="1" style="width: 100%; border-collapse: collapse;"> <tr><td>0</td><td>3</td><td>.</td><td>S</td><td>C</td><td>S</td><td>I</td><td></td><td>I</td><td>D</td><td></td><td></td><td></td><td></td><td></td><td></td></tr> <tr><td></td><td></td><td></td><td></td><td></td><td></td><td></td><td></td><td></td><td></td><td></td><td></td><td></td><td></td><td>N</td><td>r</td><td>.</td><td>0</td></tr> </table>	0	3	.	S	C	S	I		I	D																					N	o	.	0	0	3	.	S	C	S	I		I	D																					N	r	.	0	<p>→0 ↔ 1 ↔ 2 ↔ 3 ↔ 4 ↔ 5 ↔ 6 ↔ 7←</p> <ul style="list-style-type: none"> ● Setting the SCSI ID will be activated after turning the power off and turning it on again. 										
0	3	.	S	C	S	I		I	D																																																																						
														N	o	.	0																																																														
0	3	.	S	C	S	I		I	D																																																																						
														N	r	.	0																																																														
04 Setting the "Terminator" <table border="1" style="width: 100%; border-collapse: collapse;"> <tr><td>0</td><td>4</td><td>.</td><td>T</td><td>e</td><td>r</td><td>m</td><td>i</td><td>n</td><td>a</td><td>t</td><td>o</td><td>r</td><td></td><td></td><td></td><td></td></tr> <tr><td></td><td></td><td></td><td></td><td></td><td></td><td></td><td></td><td></td><td></td><td></td><td></td><td></td><td></td><td>D</td><td>i</td><td>s</td><td>a</td><td>b</td><td>l</td><td>e</td></tr> </table> <table border="1" style="width: 100%; border-collapse: collapse;"> <tr><td>0</td><td>4</td><td>.</td><td>T</td><td>e</td><td>r</td><td>m</td><td>i</td><td>n</td><td>a</td><td>t</td><td>o</td><td>r</td><td></td><td></td><td></td><td></td></tr> <tr><td></td><td></td><td></td><td></td><td></td><td></td><td></td><td></td><td></td><td></td><td></td><td></td><td></td><td></td><td></td><td></td><td></td><td></td><td></td><td></td><td>A</td><td>u</td><td>s</td></tr> </table>	0	4	.	T	e	r	m	i	n	a	t	o	r																			D	i	s	a	b	l	e	0	4	.	T	e	r	m	i	n	a	t	o	r																									A	u	s	<p>→Disable ↔ Enable←</p> <p>→Aus ↔ Ein←</p> <p>When the scanner is located to terminal position on SCSI bus, set to "Enable".</p> <ul style="list-style-type: none"> ● Setting the terminator will be activated after turning the power off and turning it on again.
0	4	.	T	e	r	m	i	n	a	t	o	r																																																																			
														D	i	s	a	b	l	e																																																											
0	4	.	T	e	r	m	i	n	a	t	o	r																																																																			
																				A	u	s																																																									

Display Panel Instructions

<p>05 Checking the "Roller Cleaning Warning"</p> <table border="1" data-bbox="175 339 665 401"> <tr><td>0</td><td>5</td><td>.</td><td>C</td><td>l</td><td>e</td><td>a</td><td>n</td><td></td><td>R</td><td>o</td><td>l</td><td>l</td><td>e</td><td>r</td><td></td></tr> <tr><td>W</td><td>a</td><td>r</td><td>n</td><td>i</td><td>n</td><td>g</td><td></td><td></td><td></td><td></td><td></td><td></td><td></td><td></td><td>0%</td></tr> </table> <table border="1" data-bbox="175 430 665 493"> <tr><td>0</td><td>5</td><td>.</td><td>R</td><td>e</td><td>i</td><td>n</td><td>i</td><td>g</td><td>e</td><td></td><td>W</td><td>a</td><td>l</td><td>z</td><td>e</td></tr> <tr><td>A</td><td>c</td><td>h</td><td>t</td><td>u</td><td>n</td><td>g</td><td></td><td></td><td></td><td></td><td></td><td></td><td></td><td></td><td>0%</td></tr> </table>	0	5	.	C	l	e	a	n		R	o	l	l	e	r		W	a	r	n	i	n	g									0%	0	5	.	R	e	i	n	i	g	e		W	a	l	z	e	A	c	h	t	u	n	g									0%	<p>0% : This is displayed when "Clean Roller Warning ○○%" displayed is cleared. 100% : This is displayed when the roller needs to be cleaned.</p>
0	5	.	C	l	e	a	n		R	o	l	l	e	r																																																			
W	a	r	n	i	n	g									0%																																																		
0	5	.	R	e	i	n	i	g	e		W	a	l	z	e																																																		
A	c	h	t	u	n	g									0%																																																		
<p>05 Clearing the "Roller Cleaning Warning"</p> <table border="1" data-bbox="175 617 665 679"> <tr><td>0</td><td>5</td><td>.</td><td>C</td><td>l</td><td>e</td><td>a</td><td>n</td><td></td><td>R</td><td>o</td><td>l</td><td>l</td><td>e</td><td>r</td><td></td></tr> <tr><td>W</td><td>a</td><td>r</td><td>n</td><td>i</td><td>n</td><td>g</td><td></td><td>C</td><td>l</td><td>e</td><td>a</td><td>r</td><td>=</td><td><</td><td>></td></tr> </table> <table border="1" data-bbox="175 708 665 770"> <tr><td>0</td><td>5</td><td>.</td><td>R</td><td>e</td><td>i</td><td>n</td><td>i</td><td>g</td><td>e</td><td></td><td>W</td><td>a</td><td>l</td><td>z</td><td>e</td></tr> <tr><td>H</td><td>i</td><td>n</td><td>w</td><td>e</td><td>i</td><td>s</td><td></td><td>L</td><td>ö</td><td>s</td><td>c</td><td>h</td><td>=</td><td><</td><td>></td></tr> </table>	0	5	.	C	l	e	a	n		R	o	l	l	e	r		W	a	r	n	i	n	g		C	l	e	a	r	=	<	>	0	5	.	R	e	i	n	i	g	e		W	a	l	z	e	H	i	n	w	e	i	s		L	ö	s	c	h	=	<	>	<p>When pressing the ► key and the ◀ key simultaneously, "Clean Roller Warning" will be cleared. Then "Completed" will be displayed.</p>
0	5	.	C	l	e	a	n		R	o	l	l	e	r																																																			
W	a	r	n	i	n	g		C	l	e	a	r	=	<	>																																																		
0	5	.	R	e	i	n	i	g	e		W	a	l	z	e																																																		
H	i	n	w	e	i	s		L	ö	s	c	h	=	<	>																																																		
<p>06 Checking the roller modules replacement warning</p> <table border="1" data-bbox="175 907 665 969"> <tr><td>0</td><td>6</td><td>.</td><td>R</td><td>e</td><td>p</td><td>l</td><td>a</td><td>c</td><td>e</td><td></td><td>R</td><td>o</td><td>l</td><td>l</td><td>.</td></tr> <tr><td>W</td><td>a</td><td>r</td><td>n</td><td>i</td><td>n</td><td>g</td><td></td><td></td><td></td><td></td><td></td><td></td><td></td><td></td><td>0%</td></tr> </table> <table border="1" data-bbox="175 998 665 1060"> <tr><td>0</td><td>6</td><td>.</td><td>T</td><td>a</td><td>u</td><td>s</td><td>c</td><td>h</td><td>e</td><td></td><td>W</td><td>a</td><td>l</td><td>z</td><td>e</td></tr> <tr><td>A</td><td>c</td><td>h</td><td>t</td><td>u</td><td>n</td><td>g</td><td></td><td></td><td></td><td></td><td></td><td></td><td></td><td></td><td>0%</td></tr> </table>	0	6	.	R	e	p	l	a	c	e		R	o	l	l	.	W	a	r	n	i	n	g									0%	0	6	.	T	a	u	s	c	h	e		W	a	l	z	e	A	c	h	t	u	n	g									0%	<p>0% : This is displayed when "Replace Roll. Warning ○○%" displayed is cleared. 100% : This is displayed when the roller modules need to be replaced.</p>
0	6	.	R	e	p	l	a	c	e		R	o	l	l	.																																																		
W	a	r	n	i	n	g									0%																																																		
0	6	.	T	a	u	s	c	h	e		W	a	l	z	e																																																		
A	c	h	t	u	n	g									0%																																																		
<p>06 Clearing the roller modules replacement warning</p> <table border="1" data-bbox="175 1185 665 1247"> <tr><td>0</td><td>6</td><td>.</td><td>R</td><td>e</td><td>p</td><td>l</td><td>a</td><td>c</td><td>e</td><td></td><td>R</td><td>o</td><td>l</td><td>l</td><td>.</td></tr> <tr><td>W</td><td>a</td><td>r</td><td>n</td><td>i</td><td>n</td><td>g</td><td></td><td>C</td><td>l</td><td>e</td><td>a</td><td>r</td><td>=</td><td><</td><td>></td></tr> </table> <table border="1" data-bbox="175 1276 665 1338"> <tr><td>0</td><td>6</td><td>.</td><td>T</td><td>a</td><td>u</td><td>s</td><td>c</td><td>h</td><td>e</td><td></td><td>W</td><td>a</td><td>l</td><td>z</td><td>e</td></tr> <tr><td>H</td><td>i</td><td>n</td><td>w</td><td>e</td><td>i</td><td>s</td><td></td><td>L</td><td>ö</td><td>s</td><td>c</td><td>h</td><td>=</td><td><</td><td>></td></tr> </table>	0	6	.	R	e	p	l	a	c	e		R	o	l	l	.	W	a	r	n	i	n	g		C	l	e	a	r	=	<	>	0	6	.	T	a	u	s	c	h	e		W	a	l	z	e	H	i	n	w	e	i	s		L	ö	s	c	h	=	<	>	<p>When pressing the ► key and the ◀ key simultaneously, "Replace Roll. Warning" will be cleared. Then "Completed" will be displayed.</p>
0	6	.	R	e	p	l	a	c	e		R	o	l	l	.																																																		
W	a	r	n	i	n	g		C	l	e	a	r	=	<	>																																																		
0	6	.	T	a	u	s	c	h	e		W	a	l	z	e																																																		
H	i	n	w	e	i	s		L	ö	s	c	h	=	<	>																																																		

“Setting the Double Feed detector action” has been added to the items for the OTHERS key of the scanner. Please take notice, together with the operating instructions.

10 Setting the “Double Feed” detector action

1	0	.	D	o	u	b	l	e	F	e	e	d		
			A	c	t	i	o	n			H	o	s	t

1	0	.	D	o	p	p	e	l	e	i	n	z	u	g		
			H	a	n	d	l	u	n	g			H	o	s	t

→Host ↔ Stop ↔ Buzzer ←

→Host ↔ Halt ↔ Summer ←

Host : The scanner will act in response to commands from the host computer.

Stop : The scanner will display double feeding error and stop when it detects double feeding.

Buzzer : When the scanner detects double feeding, it will sound a buzzer, the power indicator will light red and it will continue scanning.

After completing scanning, the scanner will display double feeding warning.

- When scanning very important documents, confirm if the number of scanned pages displayed on the LCD matches the number of actual pages.
- If thick, creased, or edited documents with correction fluid as well as documents with holes near the center, etc., are used, they may detect double feeding by mistake.
- When scanning a document which is shorter than 210 mm / 8.3" (A5 size) in length, double feed detection will not work well.

スキャナーの OTHERS キーによる設定に、「重送検知動作設定」が追加になりました。
取扱説明書と合わせて、よくお読みください。

10 重送検知動作設定

1	0	.	シ	ユ	ウ	ソ	ウ	ケ	ン	チ	ド	.	ウ	サ
													ホ	スト

→ ホスト ↔ テイシ ↔ ブザー ←

ホスト：ホストコンピューターの指示に従います。

テイシ：重送を検知した場合は重送エラーを表示し停止します。

ブザー：重送を検知した場合はブザーを鳴らし、電源ランプを赤く点灯し、読み取りを続けます。読み取りが終了した後、重送警告を表示します。

- 特に重要な原稿を読み取るときは、本機の液晶ディスプレイに表示される原稿枚数と実際に読み取られた原稿枚数が合っているかどうかを、必ず確認してください。
- 厚手の原稿・しわの多い原稿・修正液で処理された原稿、および中心部付近に穴のある原稿などは、誤って重送と検知されることがあります。
- 読み取り方向の長さが 210 mm より短い原稿を読み取るときは、重送検知が働きません。

07 Setting the "Product ID"

0	7	.	P	r	o	d	u	c	t	I	D						
										K	V	-	S	6	0	4	5

0	7	.	P	r	o	d	u	k	t	I	D						
										K	V	-	S	6	0	4	5

● KV-S6045W series

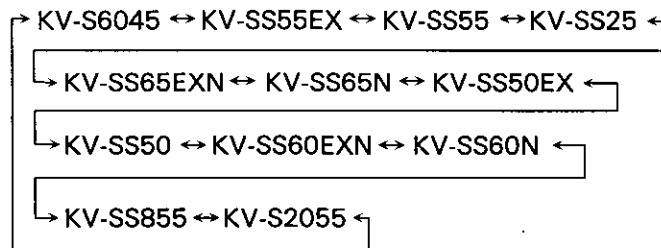

● KV-S6040W series

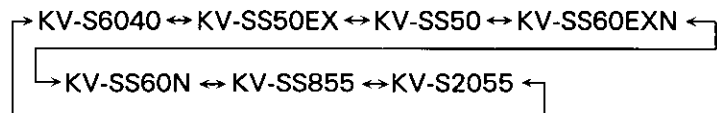

The applications for the scanner which have been set can be used.

- An error results if an attempt is made to use a function which are not provided with the KV-S6040W or KV-S6045W series of scanners.
- No guarantees are given for complete compatibility.

08 Setting the "Double Feed" detector sensitivity

0	8	.	D	o	u	b	l	e	F	e	e	d				
													H	o	s	t

0	8	.	D	o	p	p	e	l	e	i	n	z	u	g				
															H	o	s	t

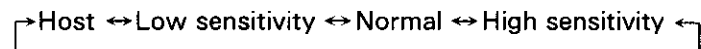

Low sensitivity : The double feed detector's sensitivity will be low. Set this when there is an error for no double feeding.

High sensitivity : The double feed detector's sensitivity will be high. Set this when there is no error for double feeding.

09 Setting the "Detect Skew"

0	9	.	D	e	t	e	c	t	S	k	e	w						
													D	e	t	e	c	t

0	9	.	S	c	h	i	e	f	e	i	n	z	u	g								
															E	r	k	e	n	n	e	n

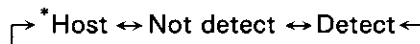

Detect : If the document is not moving straight, scanning will stop and "U20 Skew Error" will be displayed.

Not detect: The document will be scanned even if it is not moving straight.

*"Host" will be displayed when the mechanical control firmware version is 1.52 and later.

- When scanning very important documents, confirm if the number of scanned pages displayed on the LCD matches the number of actual pages.
- If thick, creased, or edited documents with correction fluid as well as documents with holes near the center, etc., are used, they may detect double feeding by mistake.
- When scanning a document which is shorter than 210mm/8.3" (A5 size) in length, double feed detection will not work well.

Display Panel Instructions

● Setting the language

1 Turn the power on while pressing the HOME key.

- When "High Speed Scanner" or other words appear on the LCD, release the HOME key.

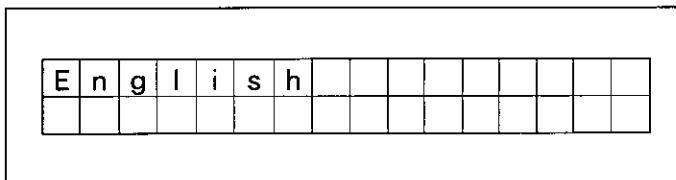

2 Use the ▲ key or the ▼ key to select "English", "Japanese" or "German".

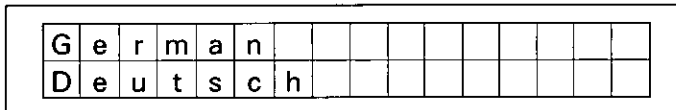

3 Press the HOME key.

- The display will change to the selected language, then the scanner will be ready.
- This setting will remain until it is changed to another setting.

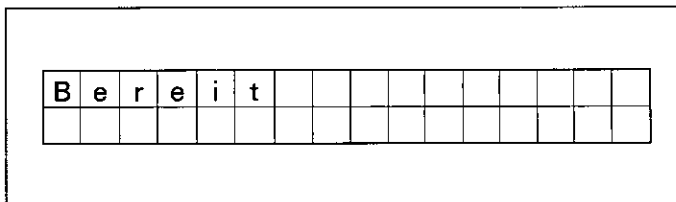

● Other display explanations

Display	Content																																																																																
<table border="1"> <tr> <td>S</td><td>c</td><td>a</td><td>n</td><td>n</td><td>i</td><td>n</td><td>g</td><td>.</td><td>.</td><td>.</td><td></td><td></td><td></td><td></td><td></td><td></td><td></td><td></td><td></td> </tr> <tr> <td></td><td></td><td></td><td></td><td></td><td></td><td></td><td></td><td></td><td></td><td></td><td></td><td></td><td></td><td></td><td></td><td></td><td></td><td></td><td>1</td> </tr> </table> <table border="1"> <tr> <td>S</td><td>c</td><td>a</td><td>n</td><td>n</td><td>i</td><td>n</td><td>g</td><td></td><td>a</td><td>k</td><td>t</td><td>i</td><td>v</td><td></td><td></td><td></td><td></td><td></td><td></td> </tr> <tr> <td></td><td></td><td></td><td></td><td></td><td></td><td></td><td></td><td></td><td></td><td></td><td></td><td></td><td></td><td></td><td></td><td></td><td></td><td></td><td>1</td> </tr> </table>	S	c	a	n	n	i	n	g	.	.	.																													1	S	c	a	n	n	i	n	g		a	k	t	i	v																										1	<p>This will be displayed when scanning is started until it is completed. After completion, "Ready" will be displayed.</p>
S	c	a	n	n	i	n	g	.	.	.																																																																							
																			1																																																														
S	c	a	n	n	i	n	g		a	k	t	i	v																																																																				
																			1																																																														
<table border="1"> <tr> <td>S</td><td>t</td><td>o</td><td>p</td><td>p</td><td>i</td><td>n</td><td>g</td><td>.</td><td>.</td><td>.</td><td>W</td><td>a</td><td>i</td><td>t</td><td>!</td><td></td><td></td><td></td><td></td> </tr> <tr> <td></td><td></td><td></td><td></td><td></td><td></td><td></td><td></td><td></td><td></td><td></td><td></td><td></td><td></td><td></td><td></td><td></td><td></td><td></td><td></td> </tr> </table> <table border="1"> <tr> <td>A</td><td>b</td><td>b</td><td>r</td><td>u</td><td>c</td><td>h</td><td>.</td><td>.</td><td>.</td><td>W</td><td>a</td><td>r</td><td>t</td><td>e</td><td>n</td><td></td><td></td><td></td><td></td> </tr> <tr> <td></td><td></td><td></td><td></td><td></td><td></td><td></td><td></td><td></td><td></td><td></td><td></td><td></td><td></td><td></td><td></td><td></td><td></td><td></td><td></td> </tr> </table>	S	t	o	p	p	i	n	g	.	.	.	W	a	i	t	!																									A	b	b	r	u	c	h	.	.	.	W	a	r	t	e	n																									<p>If the STOP key is pressed, scanning will stop. This will be displayed when the STOP key is pressed during scanning. Even if the STOP key is pressed in a setting mode, this will be displayed. Then the scanner will return to setting mode after stopping scanner operation.</p>
S	t	o	p	p	i	n	g	.	.	.	W	a	i	t	!																																																																		
A	b	b	r	u	c	h	.	.	.	W	a	r	t	e	n																																																																		
<table border="1"> <tr> <td>S</td><td>c</td><td>a</td><td>n</td><td>n</td><td>e</td><td>r</td><td></td><td>S</td><td>t</td><td>o</td><td>p</td><td>p</td><td>e</td><td>d</td><td></td><td></td><td></td><td></td><td></td> </tr> <tr> <td></td><td></td><td></td><td></td><td></td><td></td><td></td><td></td><td></td><td>1</td><td>2</td><td>3</td><td>4</td><td>5</td><td>6</td><td></td><td></td><td></td><td></td><td></td> </tr> </table> <table border="1"> <tr> <td>S</td><td>c</td><td>a</td><td>n</td><td></td><td>S</td><td>t</td><td>o</td><td>p</td><td>p</td><td></td><td>T</td><td>a</td><td>s</td><td>t</td><td>e</td><td></td><td></td><td></td><td></td> </tr> <tr> <td></td><td></td><td></td><td></td><td></td><td></td><td></td><td></td><td></td><td></td><td></td><td>1</td><td>2</td><td>3</td><td>4</td><td>5</td><td>6</td><td></td><td></td><td></td> </tr> </table>	S	c	a	n	n	e	r		S	t	o	p	p	e	d															1	2	3	4	5	6						S	c	a	n		S	t	o	p	p		T	a	s	t	e																1	2	3	4	5	6				<p>This will be displayed when the STOP key is pressed and the scanner stops. Even if the document remains in the scanner, "JAM" will not be displayed. If the document remains in the scanner, open the ADF door and the front door, then remove it. Then "Ready" will be displayed.</p>
S	c	a	n	n	e	r		S	t	o	p	p	e	d																																																																			
									1	2	3	4	5	6																																																																			
S	c	a	n		S	t	o	p	p		T	a	s	t	e																																																																		
											1	2	3	4	5	6																																																																	
<table border="1"> <tr> <td>P</td><td>r</td><td>e</td><td>s</td><td>s</td><td></td><td>S</td><td>T</td><td>A</td><td>R</td><td>T</td><td></td><td>K</td><td>e</td><td>y</td><td></td><td></td><td></td><td></td><td></td> </tr> <tr> <td></td><td></td><td></td><td></td><td></td><td></td><td></td><td></td><td></td><td></td><td></td><td></td><td></td><td></td><td></td><td></td><td></td><td></td><td></td><td></td> </tr> </table> <table border="1"> <tr> <td>T</td><td>a</td><td>s</td><td>t</td><td>e</td><td></td><td>S</td><td>T</td><td>A</td><td>R</td><td>T</td><td></td><td>d</td><td>r</td><td>.</td><td></td><td></td><td></td><td></td><td></td> </tr> <tr> <td></td><td></td><td></td><td></td><td></td><td></td><td></td><td></td><td></td><td></td><td></td><td></td><td></td><td></td><td></td><td></td><td></td><td></td><td></td><td></td> </tr> </table>	P	r	e	s	s		S	T	A	R	T		K	e	y																										T	a	s	t	e		S	T	A	R	T		d	r	.																										<p>This will be displayed after setting scanning to start with a host computer. If the document is set and the START key is pressed, scanning will start.</p>
P	r	e	s	s		S	T	A	R	T		K	e	y																																																																			
T	a	s	t	e		S	T	A	R	T		d	r	.																																																																			

※Upper display in each cell is in English and lower one is in German.

Loading Documents on the ADF

1 To prevent double feeding, separate any documents which have been stapled together or stacked, as in a file, before setting in the scanner.

- ① Fan the stack of documents to separate all of the edges.
- ② Hold both ends of the document and bend them as shown to the right.
- ③ To separate the document apart, grasp them firmly and pull them so that the center part waves as shown to the right.

Repeat the steps above as necessary.

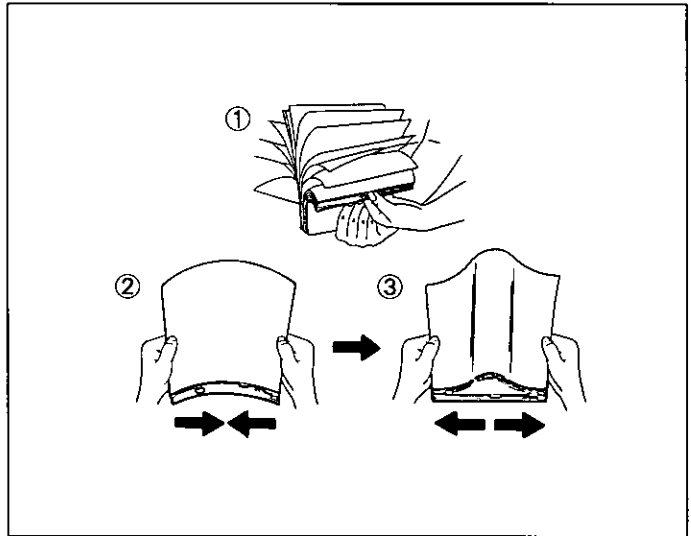

2 Carefully align the top left ends of the documents.

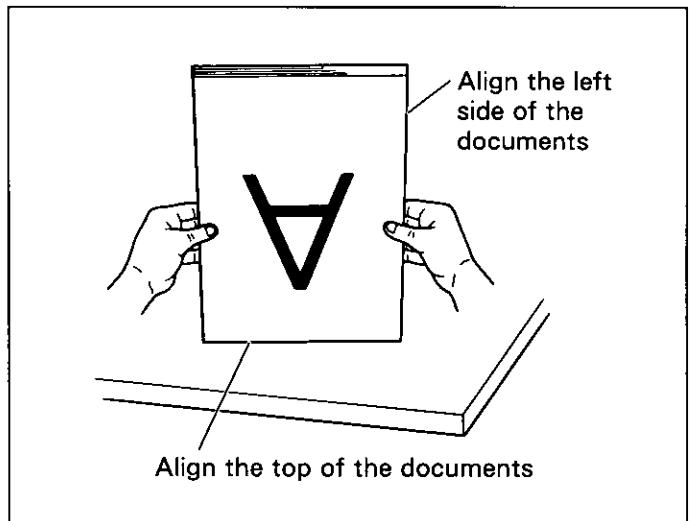

3 Adjust the document guide slightly larger than the actual size of the document.

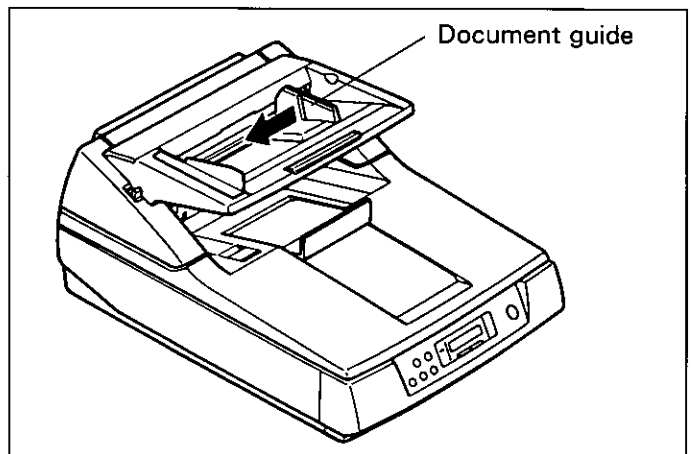

Loading Documents on the ADF

4 Place the documents on the hopper with the side to be scanned facing up. Then push them in the direction of the arrow until they stop.

- Place the documents on the hopper by matching them with the left side of the hopper as shown in the diagrams at the right. The amount of documents should not exceed the limit mark on the document guide. This may cause a paper jam or skew.
- For different sized documents, place them with the top left ends facing the left side of the hopper.

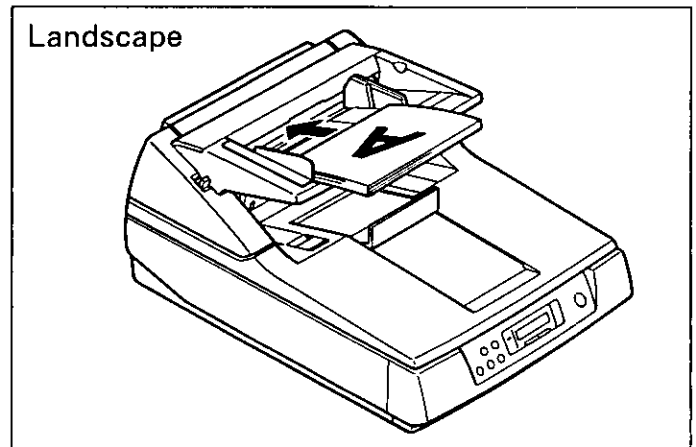
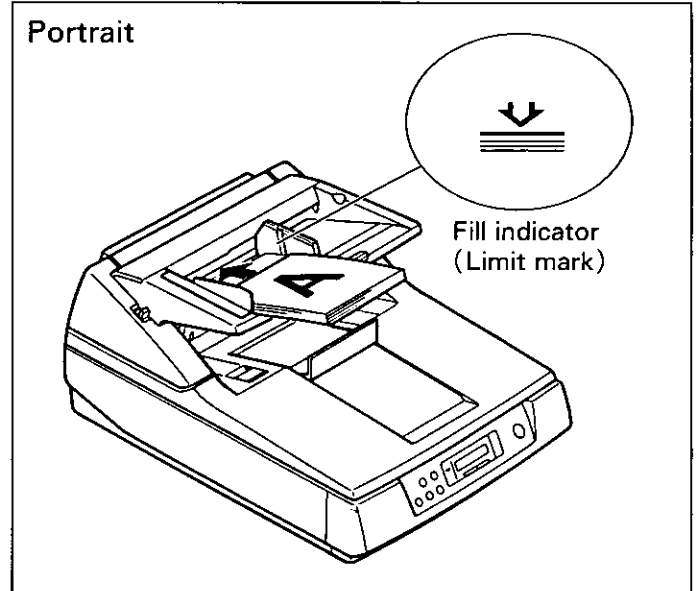

5 Adjust the document guide to the size of the document to be scanned. Adjust the exit document stopper to the size of the document to be output.

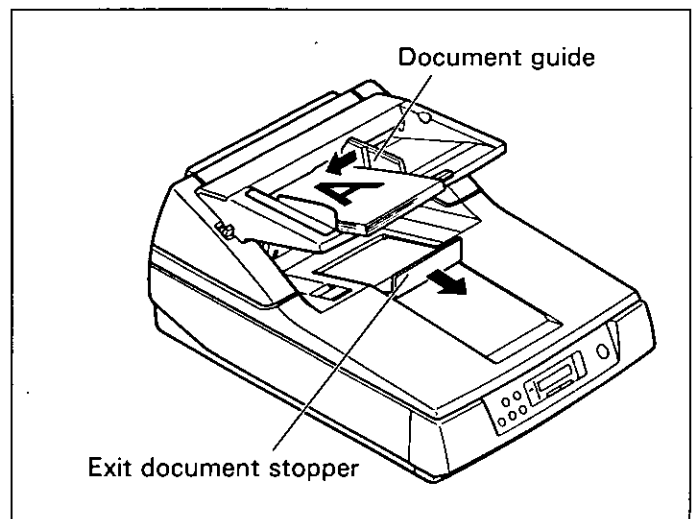

6 When using long paper, pull out the hopper extension tray from the hopper and the exit document stopper from the document cover. Then adjust the exit document stopper above the document cover a little longer than the actual length of the document by pressing down the exit document stopper slightly. (See fig. 1.)

- When scanning narrow documents as shown below, pull up the exit substopper. (See fig. 2.)

After using the exit substopper, push down it.

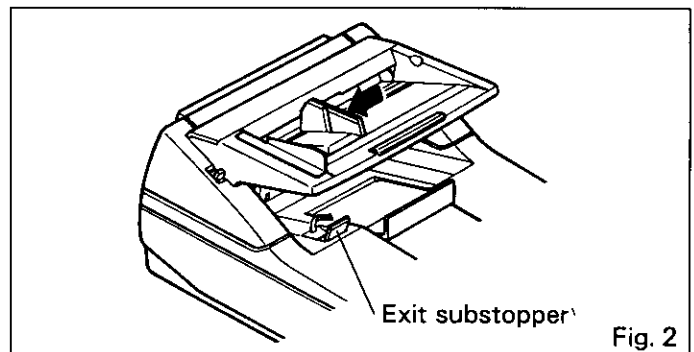
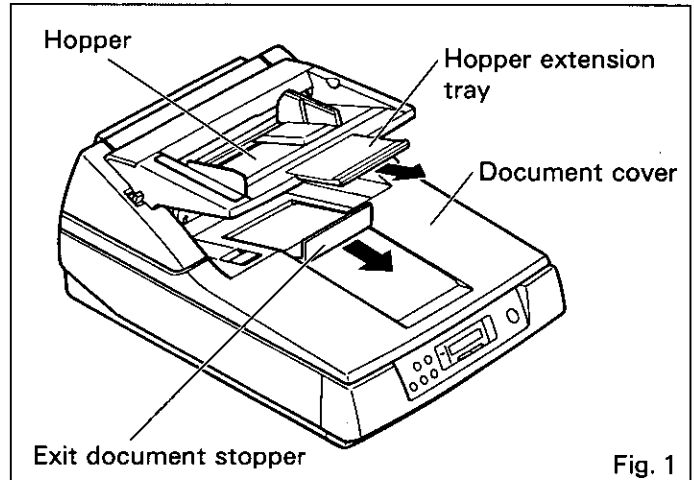
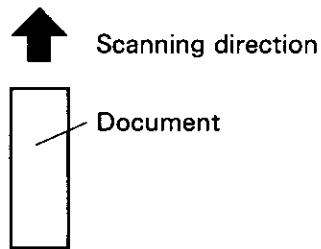

Cautions :

- When scanning very fragile documents, scan with the flatbed side. (See page 28.)
- For thin, thick or important paper, scan the document with the flatbed side or using single sheet (manual feed) mode (see page 31). Also, remove the document from the document cover after it is scanned by the ADF.
- The scanner will accept 50 to 127 g / m² (13 to 34 lbs.) paper for continuous scanning and 40 to 127 g / m² (10.6 to 34 lbs.) paper for single scanning.
- When scanning a thin, folded, creased or curled document by the ADF, after straightening the document, set the feed speed to "Slow".
- When scanning thick documents [64 g / m² (17 lbs.) or more] , be sure to use less than 200 sheets.
- When scanning copying paper such as carbon or carbonless paper, use the flatbed.
- When setting the document, be sure that it does not exceed the fill indicator (limit mark).
- Be sure to remove the document from the document cover after it is scanned.
- When the scanner does not detect a document set in the hopper which has a black or dark area on the opposite side, add a white sheet of paper under the document.
- When scanning the different sized documents, exited document may go into the stack of documents on the exit part and may get out of order.

Types of documents to avoid for the ADF :

- OHP sheets, other plastic film, cloth, or metallic sheets
- Paper with irregularities such as tabs, staples, paste, etc.
- Documents with wet ink
- Thick or irregular documents such as envelopes, paste, etc.
- Copying paper such as carbons or carbonless paper (Chemically treated carbonless forms)
Note: Scanning chemically treated paper will result in premature wear of the paper feed roller.
- Damaged or wrinkled documents
- Unusually shaped documents
- Tracing paper

Loading Documents on the Flatbed

One sheet or a book document can be scanned on the document glass.
Scanning documents in this way is known as "scanning with the flatbed".

■ When scanning with the flatbed one time

- 1 Open the document cover.

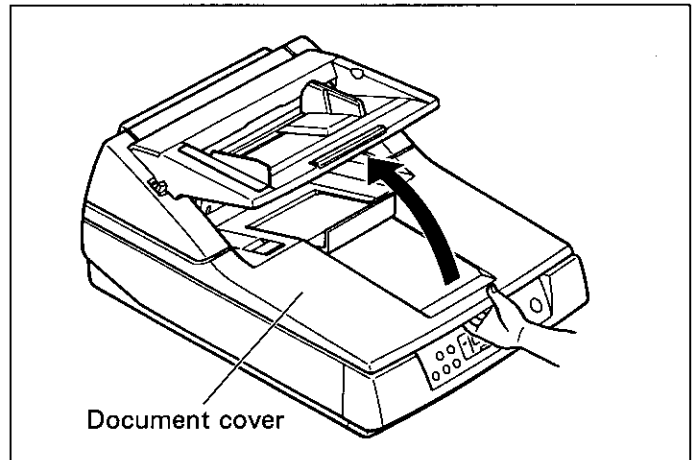

- 2 Place the scanning side of the document face down on top of the document glass.

- If the document is bent or folded, straighten it.

- 3 Match the shorter side of the document with the left edge of the document glass.

- 4 Match the longer side of the document with the standard mark.

- If the document is slanted, it will not be scanned properly.

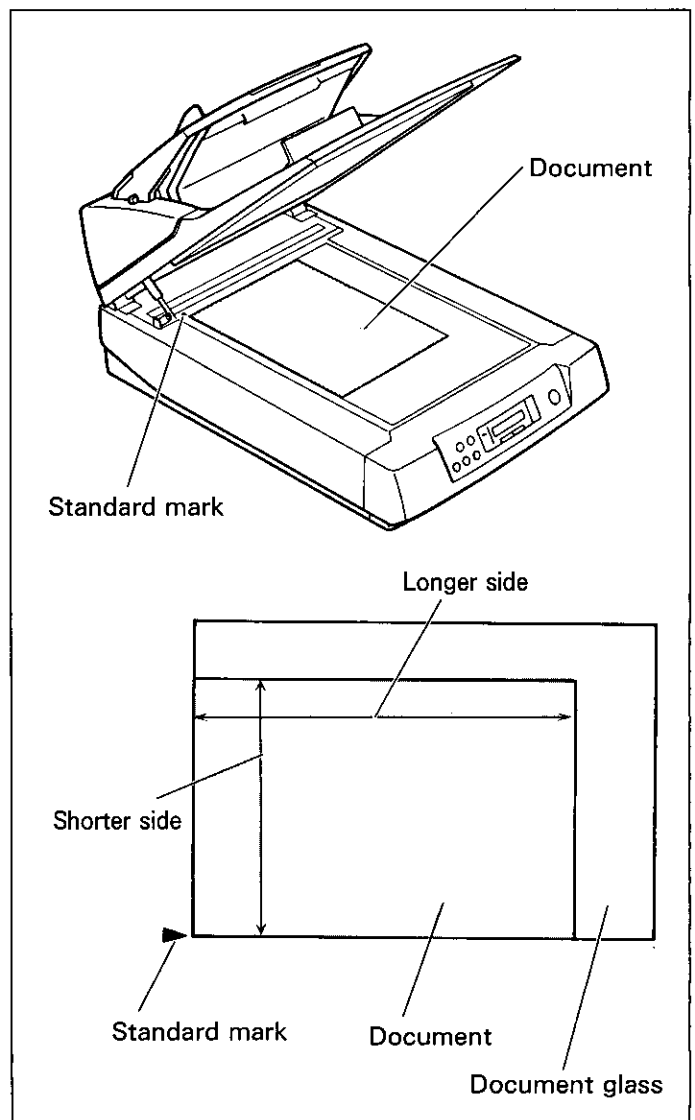

- 5** Close the document cover gently.
- If the document cover is slammed, the document will move and may not be scanned properly.
 - Do not open or press down on the document cover during scanning.
 - Do not look directly at the light. (You may damage your eyes.)
 - Be sure to close the document cover before use.
 - After scanning, open the document cover and remove the document.

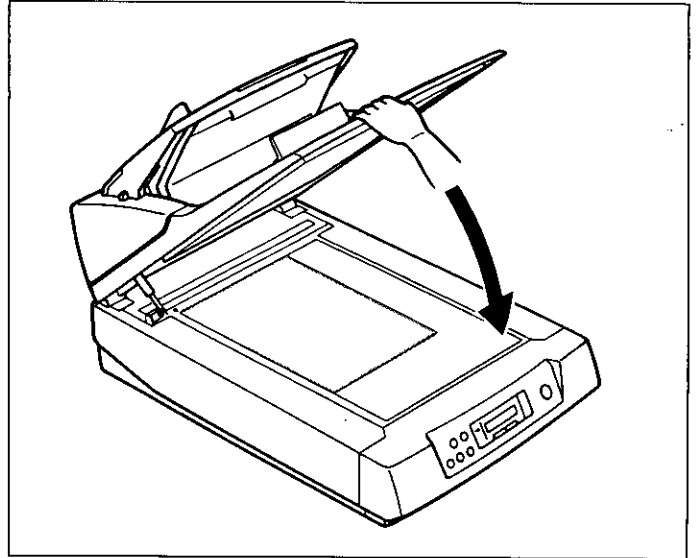

■ When scanning with the flatbed repeatedly

The ADF is heavy so when scanning with the flatbed repeatedly, separate the ADF and document cover.

- 1** Pull the exit document stopper towards you, pull the front door release under the hopper, separate the ADF and document cover, and lift up the ADF to open.

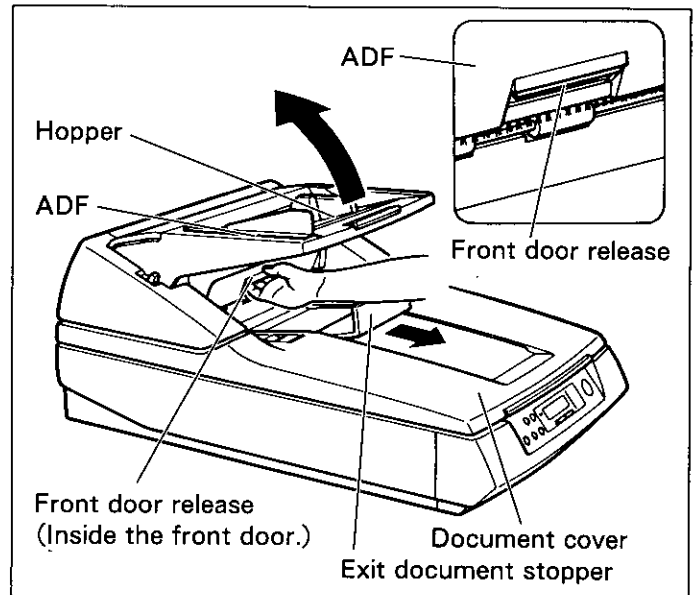

- 2** Perform operation steps 1 through 5 for scanning with the flatbed one time. (See pages 28 and 29.)

Loading Documents on the Flatbed

- 3** After scanning, close the document cover gently.

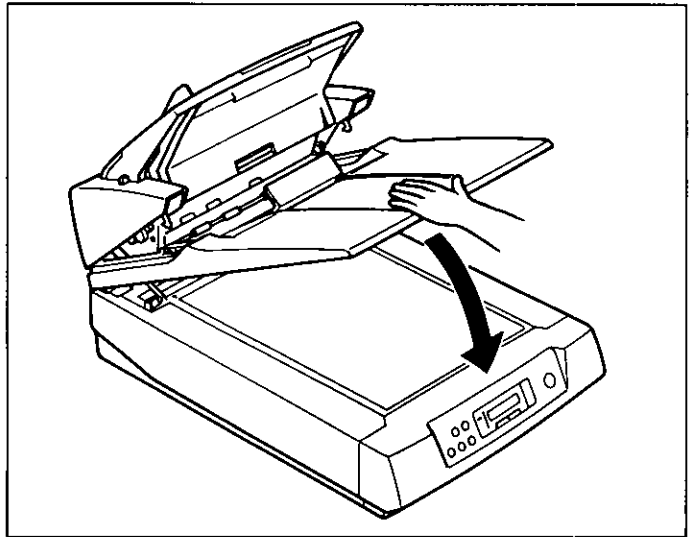

- 4** Close the ADF gently.
- Push down on both sides of the ADF gently until it clicks into place.
 - Do not close the ADF holding the hopper extension tray.

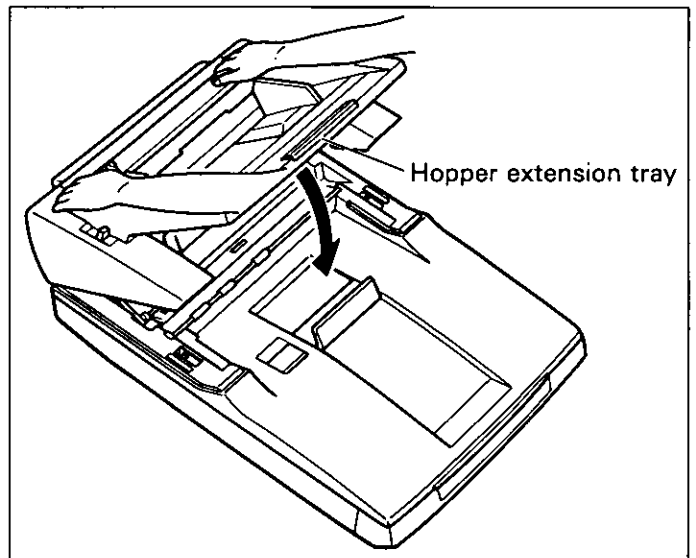

■ Scanning thick documents

When scanning thick documents such as a book, please note the following items:

- The operation methods when scanning thick document, such as a book, with the flatbed one time and repeatedly are the same.
- Do not close the document cover forcibly. You may scan with the document cover open. In this case, do not look directly at the light.
- Please note that areas of the document which are not touching the document glass will not be scanned properly.
- If the document moves during scanning, please note that it will not be scanned properly.

Feeding a Document Manually

When scanning a document with multiple pages with the ADF, set the manual feed selector to "MANUAL" and the pages can be scanned one page at a time.

1 Set the manual feed selector to "MANUAL".

- The hopper will then be raised to the proper level for manual feeding.

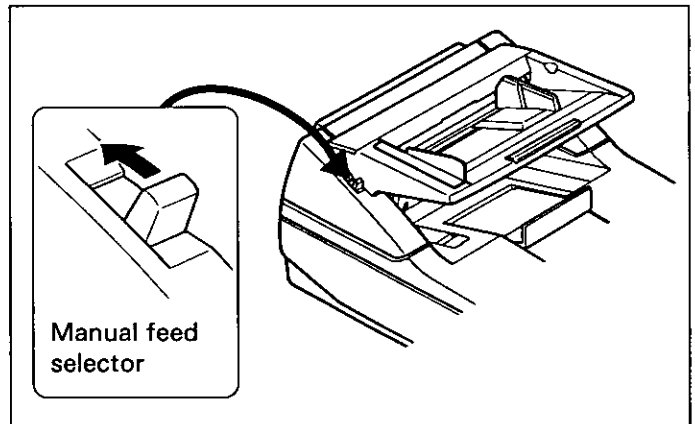

2 Match the document guide with the size of the document.

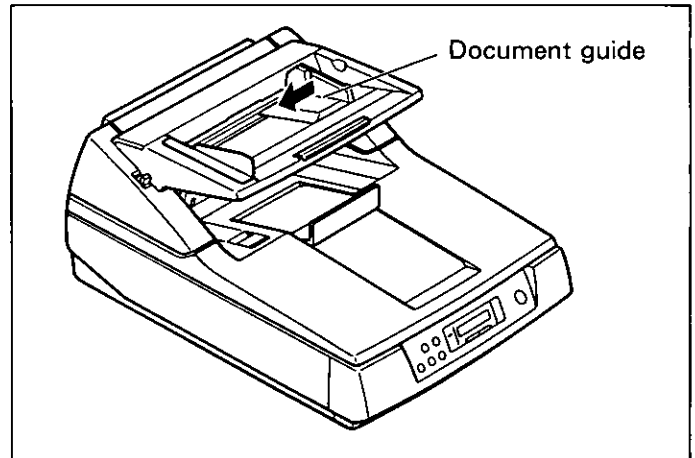

3 Insert the document into the paper slot one page at a time.

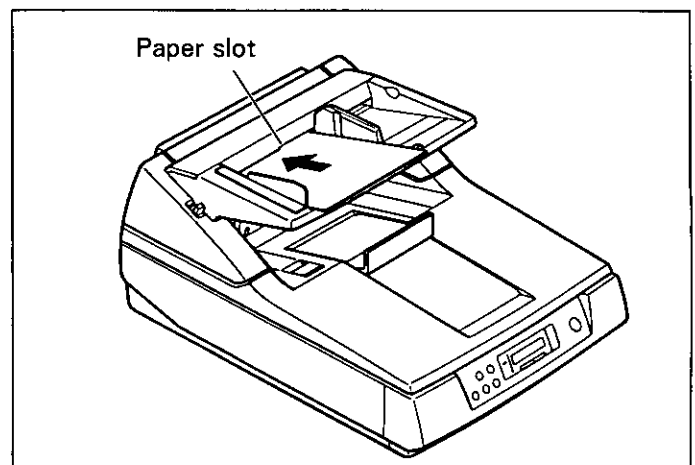

Cautions :

- Please remove any staples from the document before use with this scanner.
- Glued or curled documents may cause a paper jam or damage the unit, so please scan using the flatbed.

Clearing Paper Jams

Torn documents, thin documents or documents that are creased on the top edge may cause paper jams. If a paper jam occurs ("U xx JAM" will be displayed on the LCD), remove the jammed sheet according to the following procedure.

■ Removing paper jams from the feed part

Using your fingers, hold down the ADF door release. Open the ADF door and pull the jammed document towards the feed part, and then close the ADF door.

- Push both sides of the ADF door down gently until it clicks into place.
- Since the roller are located on the left side of the ADF door, there is more weight on the left side. Therefore, it is important to note that the door needs to have tension evenly divided to close it properly.

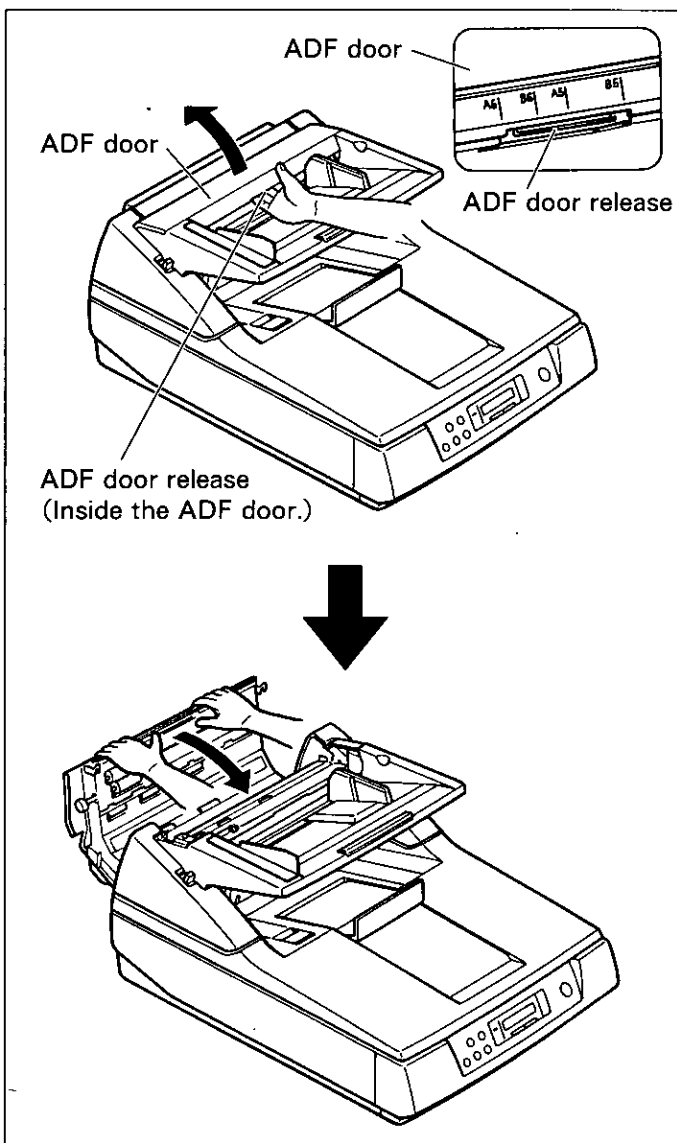

■ Removing paper jams from the exit part

If a jammed document appears at the exit part, pull the exit document stopper towards you, open the front door and pull the document forward, then close the front door.

- Push both sides of the front door down gently until it clicks into place.
- Do not close the front door holding the hopper extension tray.

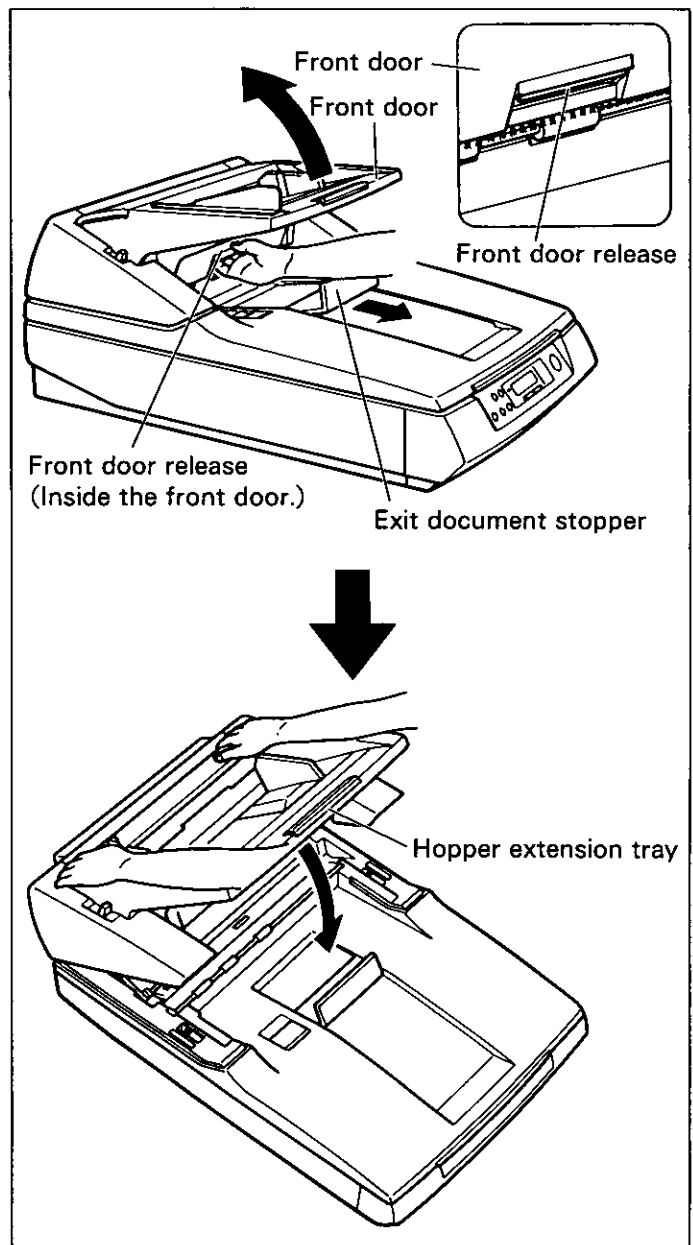

Cleaning the Unit

■ Outside of the scanner

Clean the unit at least once a month.

- 1 Turn the power off.
- 2 Clean the cover with a soft cloth.
 - The ADF insertion and exit slots get dirty easily, therefore, proper cleaning is required.
- 3 Remove dirt and dust from the fan exhaust vent with a brush.

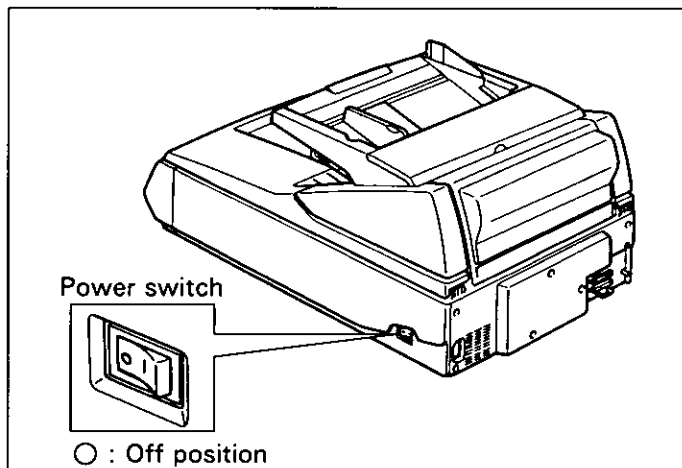

■ Inside the scanner

Clean the unit described below at least once a week or when 10,000 sheets have been scanned, whichever comes first.

- Clean the rollers, all document sensors, double feed detection sensors and paper detection sensor if paper jamming or double feeding occurs frequently.
- Clean the scanning section glass, CIS glass, white plate and white sensor roller when black or white lines appear on the scanned images. NOTE : There is no CIS glass and no white sensor roller for the KV-S6040W/KV-S6040WU.
- If the documents that will be scanned are dirty, then the scanner parts may become dirty as well. To maintain proper scanning, clean the scanner parts frequently.
- When scanning with the flatbed and black dots or white patches occur, open the document cover, and clean the document glass and cover sheet (white sheet) using the accessory roller cleaning paper.

■ Cleaning the rollers

- 1 Turn the power off.
- 2 Using your fingers, hold down the ADF door release, then open the ADF door completely.

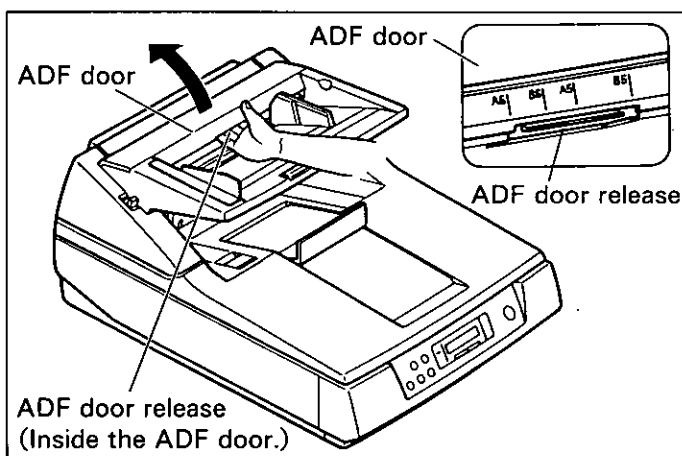

3 Use the accessory roller cleaning paper (KV-SS03) to remove the dirt from the surfaces of all rollers.

- When wiping off the dirt, hold the rollers to prevent them from rotating. Wipe the rollers completely from one end to the other. Be sure to wipe in the directions of the arrows shown on the diagram to the right.
- Clean the retard roller only in the directions of the arrow shown on the diagram to the right. If cleaned in the wrong direction, the roller may slip out of the proper position.

- The rollers to be cleaned are shaded.
- Wipe in the direction of the arrows.

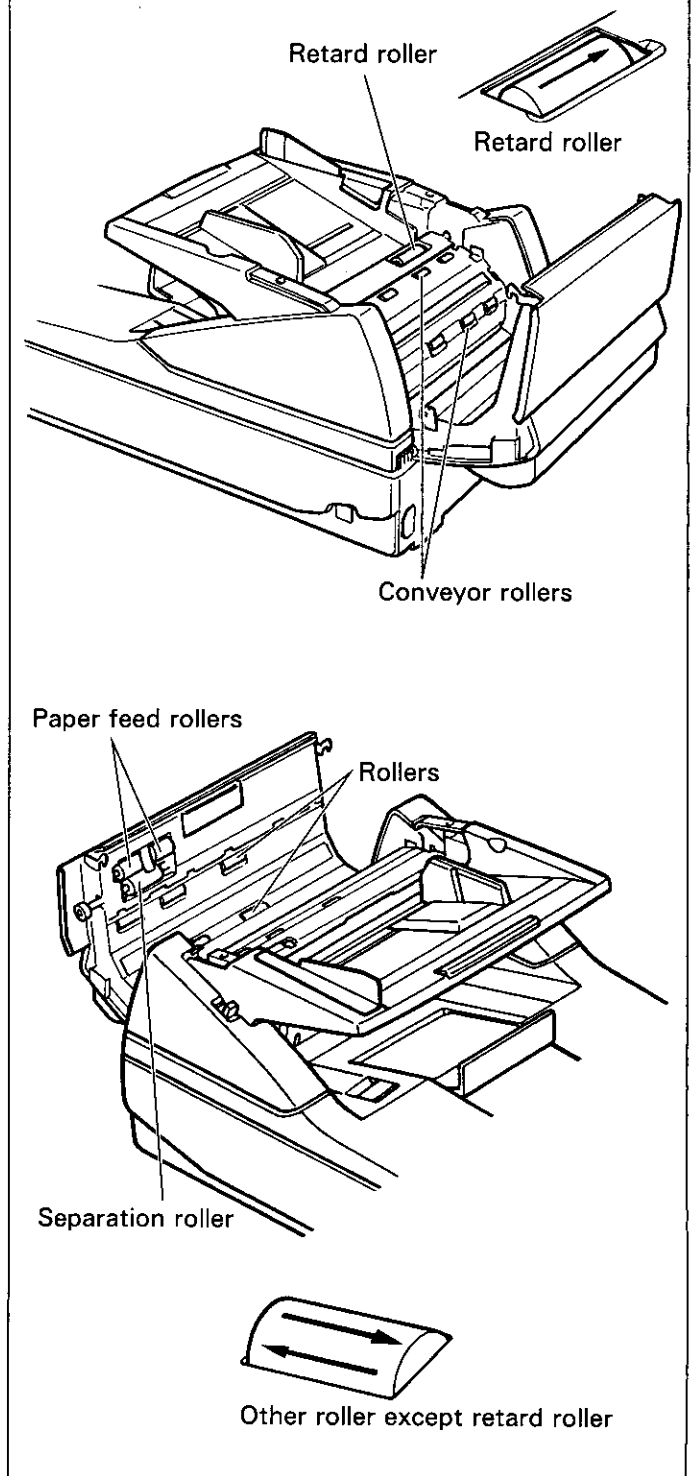

Cleaning the Unit

- 4** Pull the exit document stopper towards you and use your fingers to hold down the front door release. Then open the front door completely.

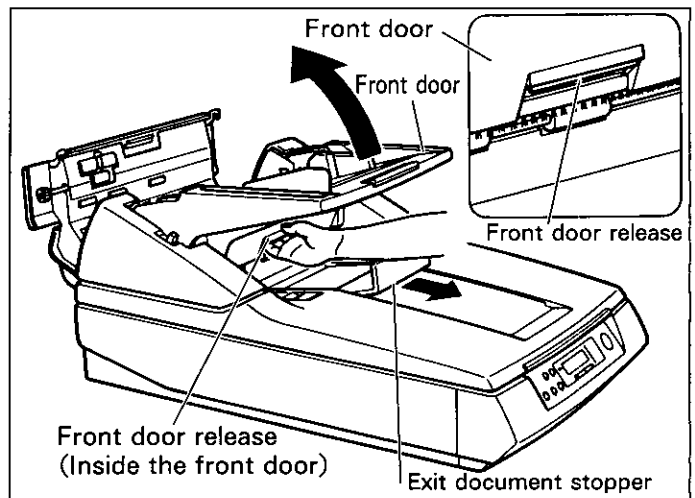

- 5** Use the accessory roller cleaning paper (KV-SS03) to remove the dirt from the surfaces of all rollers.

- When wiping off the dirt, hold the rollers to prevent them from rotating. Wipe the rollers completely from one end to the other. Be sure to wipe in the directions of the arrows shown on the diagram to the right.

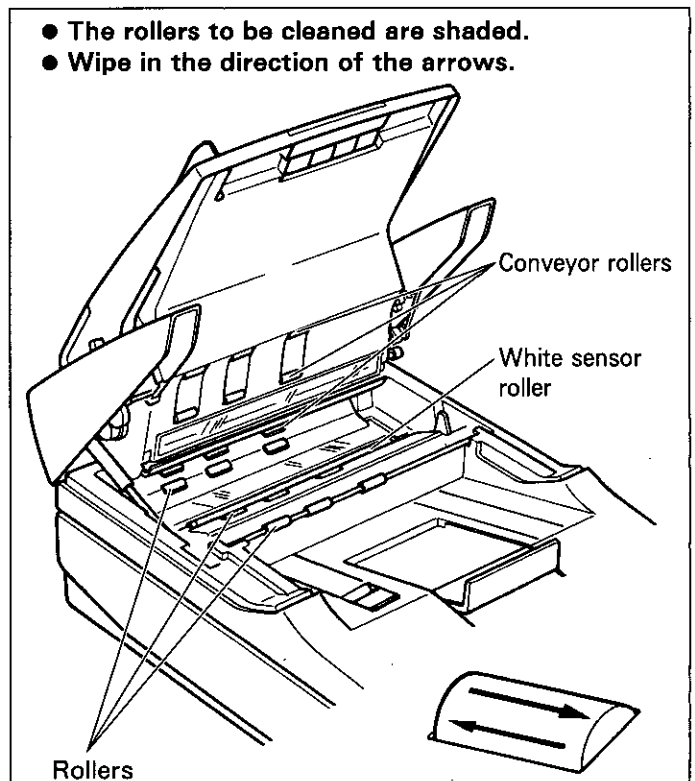

- The rollers to be cleaned are shaded.
- Wipe in the direction of the arrows.

- 6** Close the front door.
- Push both sides of the front door down gently until it clicks into place.
 - Do not close the front door holding the hopper extension tray.

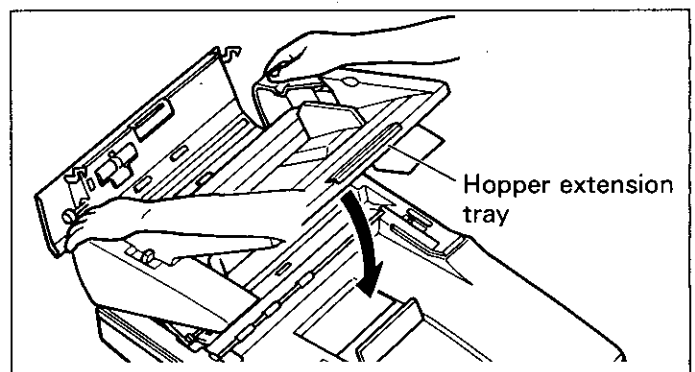

- 7** Close the ADF door.
- Push both sides of the ADF door down gently until it clicks into place.
 - Since the roller are located on the left side of the ADF door, there is more weight on the left side. Therefore, it is important to note that the door needs to have tension evenly divided to close it properly.

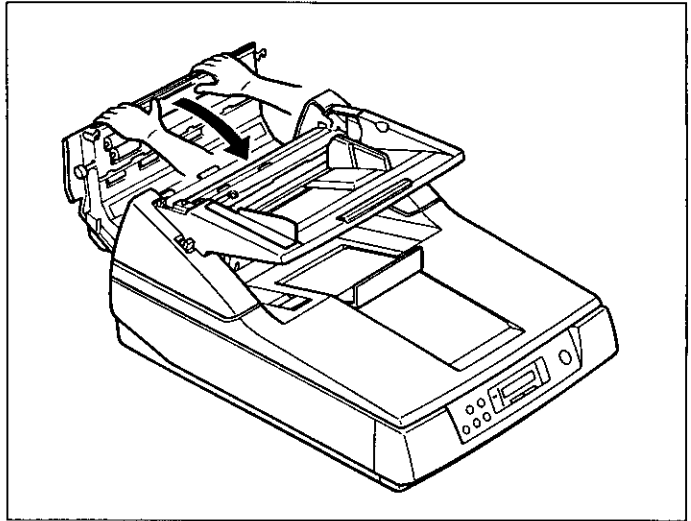

■ Cleaning the scanning section glass, CIS glass, white plate, white sensor roller, document sensors, double feed detection sensors and paper detection sensor

- 1** Turn the power off.
- 2** Using your fingers, hold down the ADF door release, then open the ADF door completely.

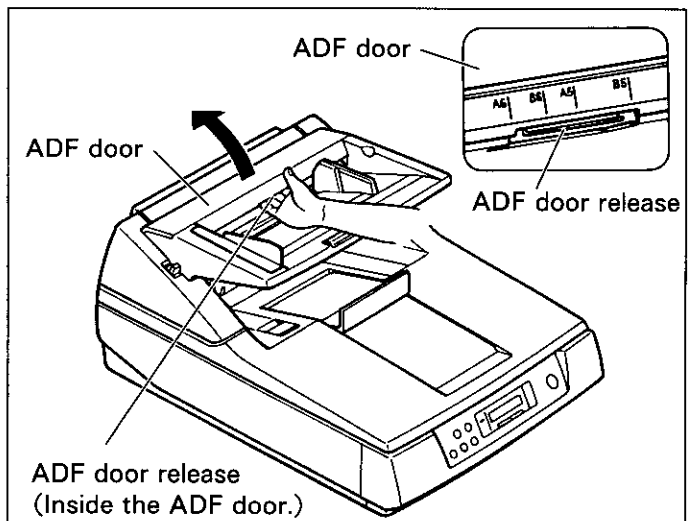

Cleaning the Unit

- 3 Remove the dirt on the document sensors, double feed detection sensors and paper detection sensor using the included blower.

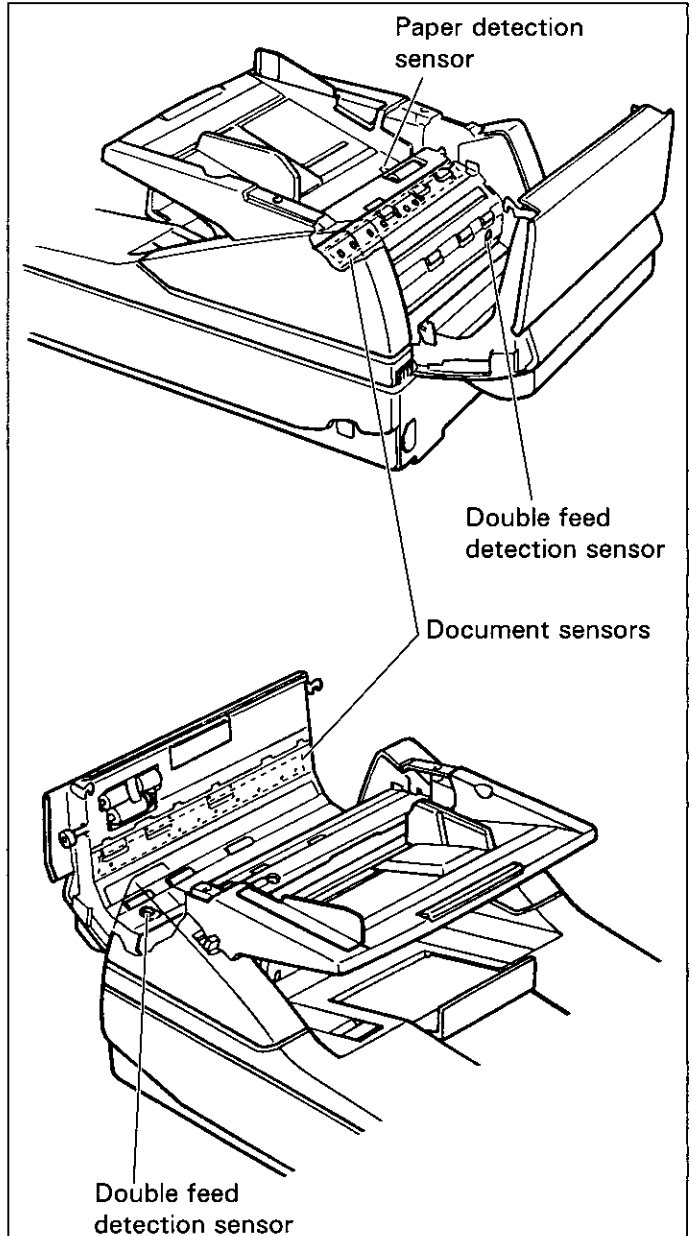

● How to clean the document sensor, double feed detection sensor or paper detection sensor

Remove the brush and blow off the dirt through the document sensor hole, double feed detection sensor hole or paper detection sensor hole.

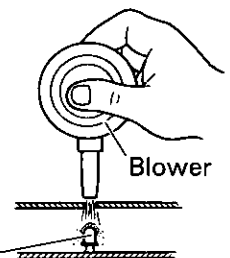

Document sensor, double feed detection sensor or paper detection sensor

- 4** Pull the exit document stopper towards you, using your fingers, hold down the front door release, then open the front door completely.

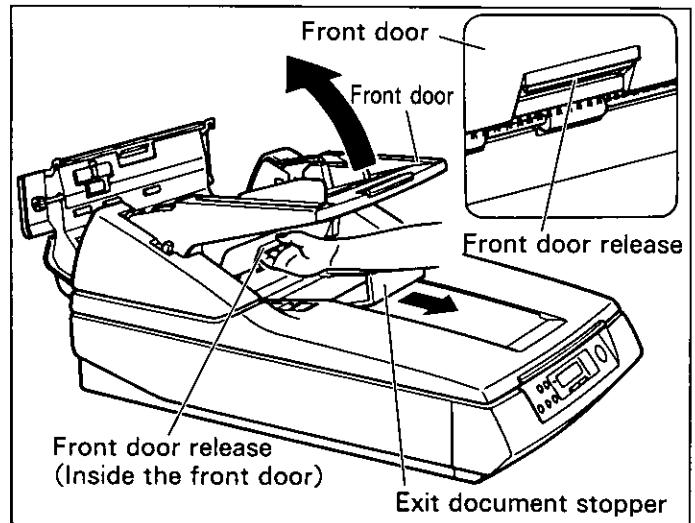

- 5** Clean the scanning section glass, CIS glass, white plate and white sensor roller using the accessory roller cleaning paper (KV-SS03). Also, remove the dirt on the document sensors using the included blower.

- If the white sensor roller is removed while cleaning, re-attach it after cleaning. (Refer to page 40 for re-attachmant.)
- There is no CIS glass and no white sensor roller for the KV-S6040W / KV-S6040WU.

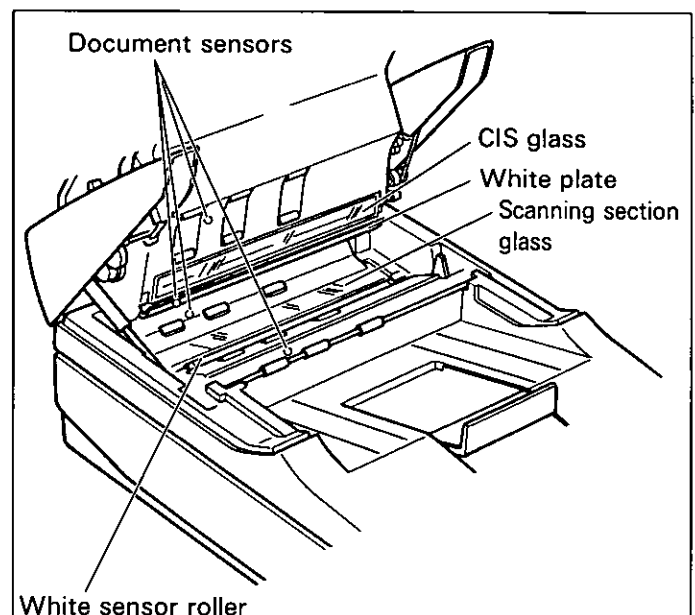

● How to clean the document sensor

Remove the brush and blow off the dirt through the document sensor hole or directly.

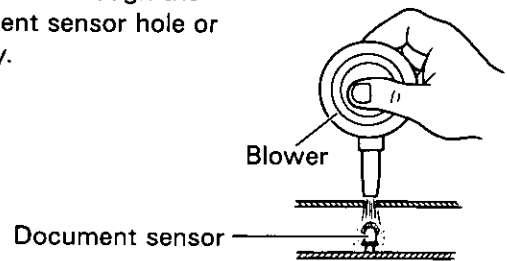

Cleaning the Unit

6 Close the front door.

- Push both sides of the front door down gently until it clicks into place.
- Do not close the front door holding the hopper extension tray.

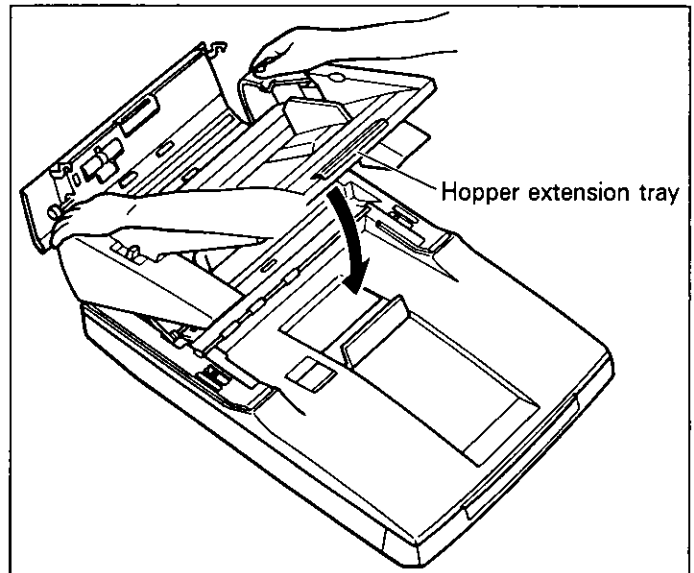

7 Close the ADF door.

- Push both sides of the ADF door down gently until it clicks into place.
- Since the rollers are located on the left side of the ADF door, there is more weight on the left side. Therefore, it is important to note that the door needs to have tension evenly divided to close it properly.
- After cleaning, clear the "Clean Roller Warning" display. (See page 22.)

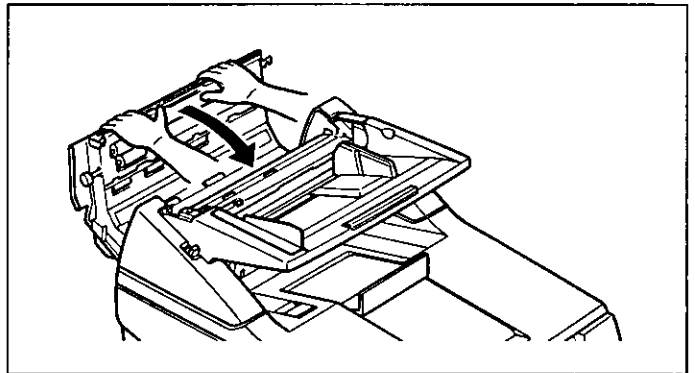

● Re-attachment of the white sensor roller

When the white sensor roller is removed while cleaning the inside of the scanner, re-attach it as shown below.

Lower white sensor roller:

Attach the roller by placing the no-gear side to the left side of the scanner and inserting both side's bearings into the guide grooves.

- Match the flat side of the bearing with the flat side of the guide groove.
- After attaching, press down on top of the white sensor roller with your finger to confirm if it moves or not.

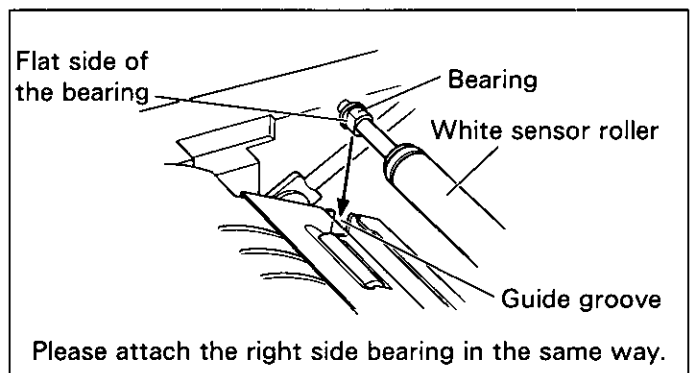

■ Document glass and cover sheet

- 1** Open the document cover.
(See step 1 on page 28.)
- 2** Clean the document glass and cover sheet (white sheet) using the accessory roller cleaning paper (KV-SS03).

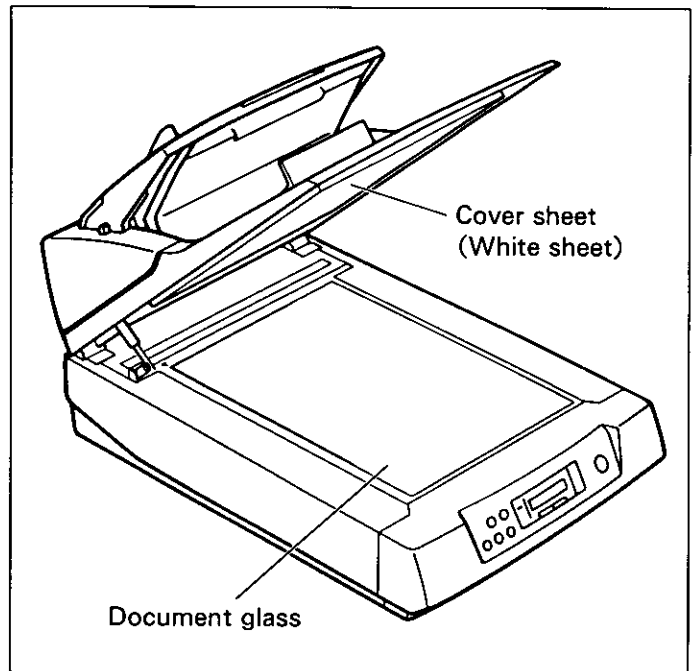

- 3** Close the document cover gently.
(See step 5 on page 29.)

■ Roller cleaning paper

Open the bag on the dotted line and take out the roller cleaning paper.

- If the roller cleaning paper bag is left open for a long period of time before using it, the alcohol will evaporate. Please use the roller cleaning paper immediately after opening the bag.

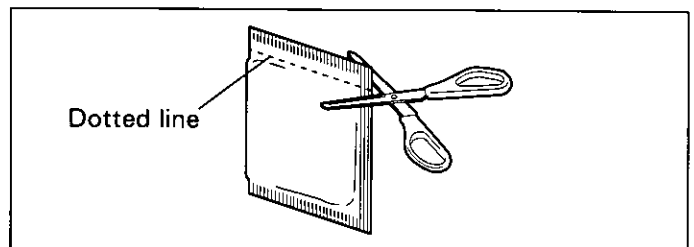

※The roller cleaning paper (Model No. KV-SS03) is available from the dealer where you purchased your scanner.
For supplies and accessories: Call 1-800-346-4768 (U. S. A. only) or your dealer.

Replacing Consumable Roller Modules

If "Warning Replace Roller" message is displayed on the LCD, replace the paper feed roller module, separation roller module and retard roller module at the same time.

1 Confirm that the manual feed selector is set to "AUTO", turn the power off and unplug the power cord.

- If the power is turned off with the manual feed selector set to "MANUAL", the retard roller module cannot be removed.

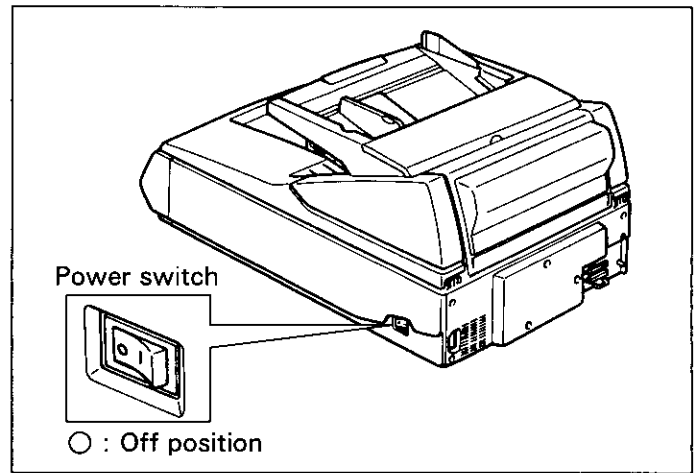

2 Using your fingers, hold down the ADF door release, then open the ADF door completely.

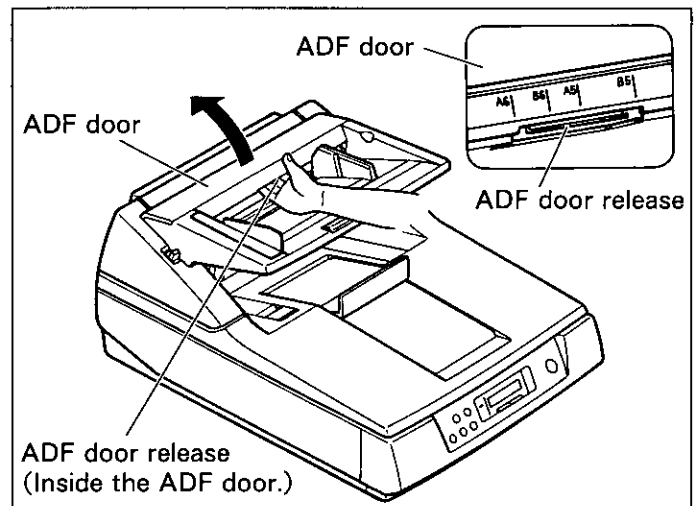

3 Using your fingers, hold the paper feed conveyor and pull it towards you to open it.

- When the paper feed conveyor is pulled towards you, the click-stop mechanism will be released.

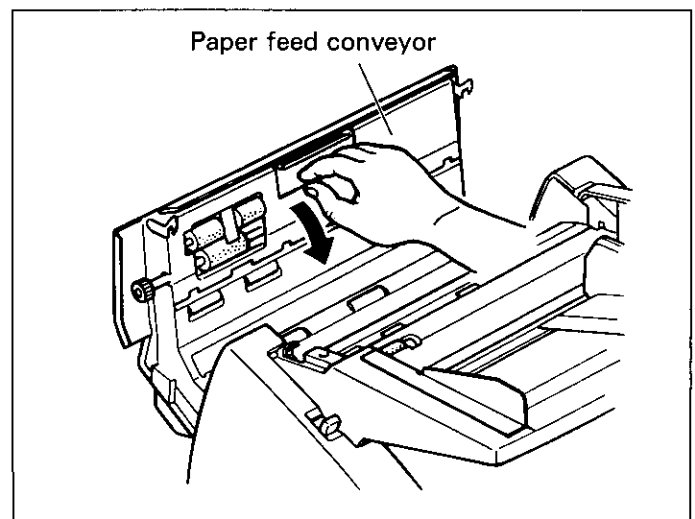

4 Remove the paper feed conveyor by first lifting it slightly and then pulling it toward you.

- Do not apply any force or weight to the paper feed conveyor since doing so may bend it out of shape.

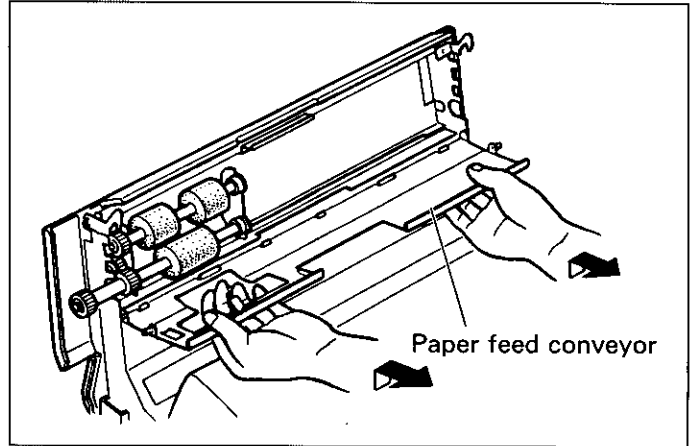

5 Hold the paper feed roller module gear and pull the gear side in the direction of arrow ①. Now slide the gear side in the direction of arrow ②.

Next, hold the separation roller module gear and pull the gear side in the direction of arrow ①, and then slide it in the direction of arrow ② to remove it.

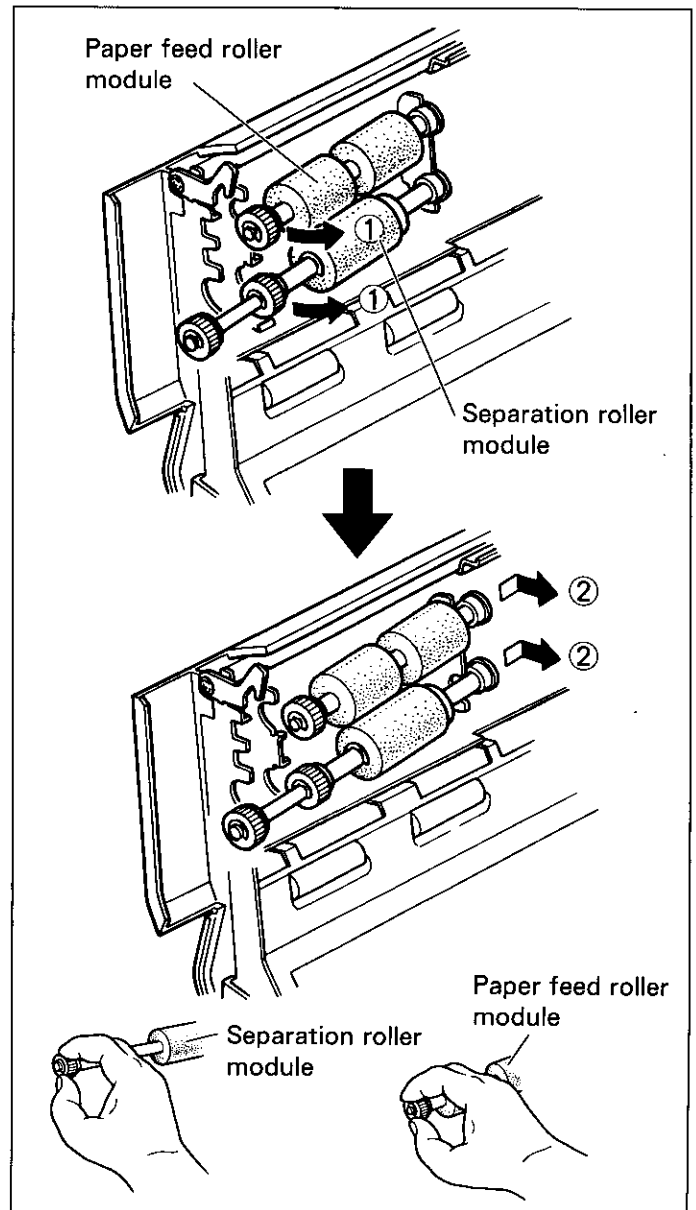

Replacing Consumable Roller Modules

- 6** Open the optional "Roller Exchange Kit (KV-SS044)", and take out the paper feed roller module and separation roller module.

For supplies and accessories:

Call 1-800-346-4768 (U. S. A. only)
or your dealer.

- 7** Install the new paper feed roller module and separation roller module with the gears on the left side and the post-gear side bearing slide into the right side guide grooves of the chassis in the scanner. (1)

Then push up the gear side bearings and install into the left side guide grooves of the chassis in the scanner. When installing the second one, it clicks into place. (2)

- Match the paper feed roller module and separation roller module with the bearings and guide grooves, and then attach them.

When attaching the paper feed roller module and separation roller module, push each bearing in the direction of the arrow ← and attach.

- When attaching the paper feed roller module and separation roller module to the chassis, do not damage the rollers.

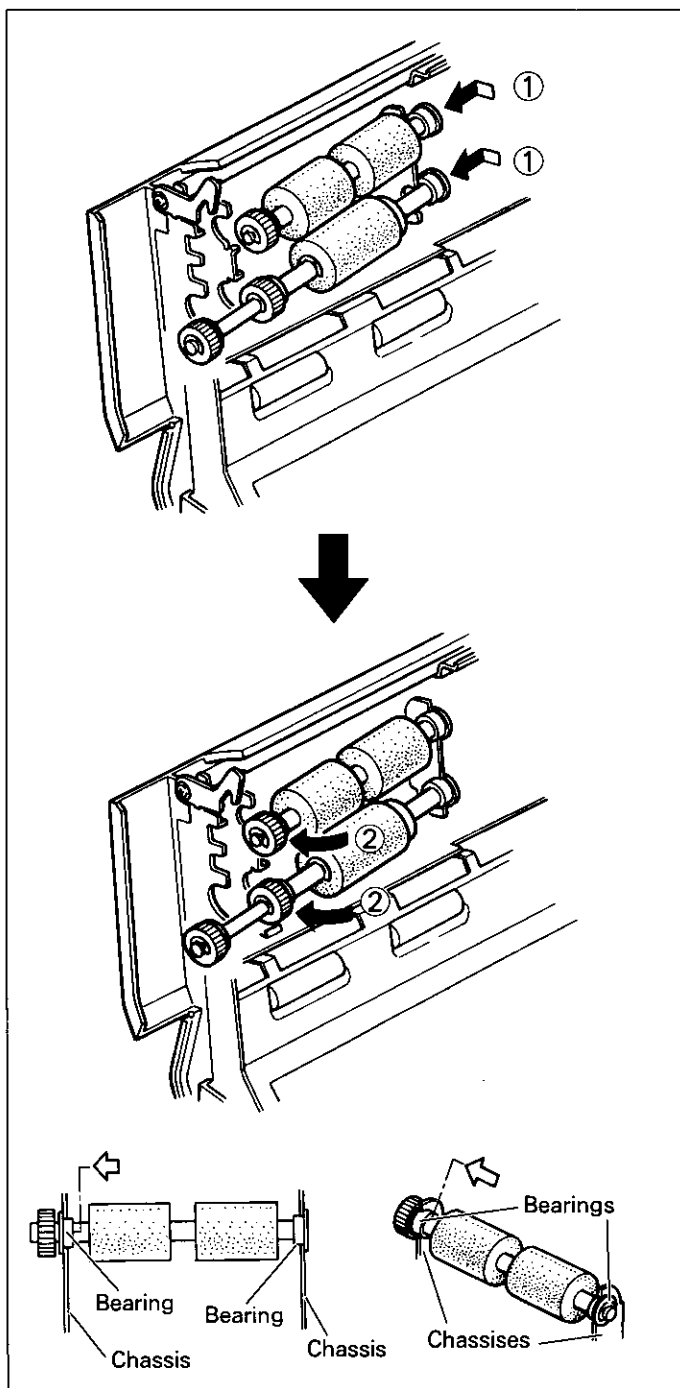

- 8** Tilt the paper feed conveyor at a slight angle pointing downward and attach it as shown in the diagram to the right.

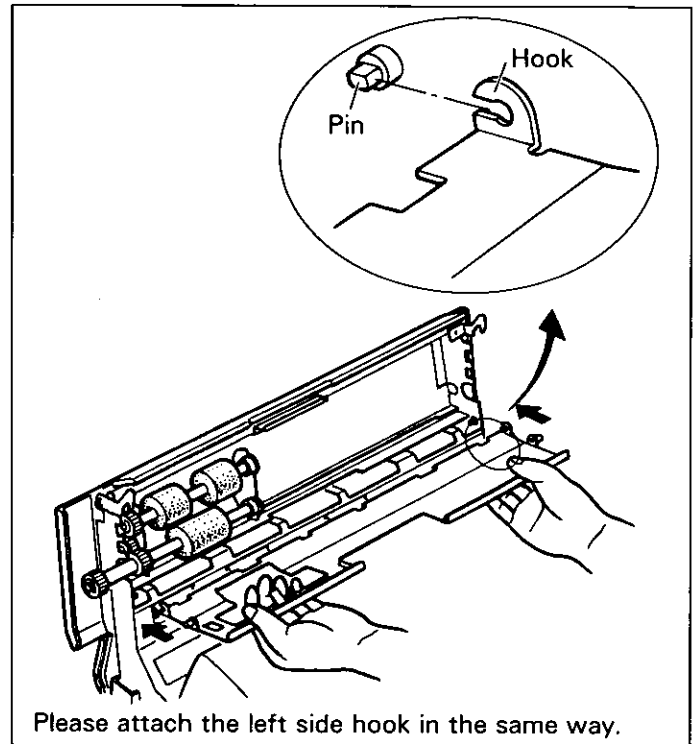

- 9** Close the paper feed conveyor.

- Push up the paper feed conveyor until it clicks into place.
- You are now finished attaching the paper feed roller module and separation roller module. To continue, replace the retard roller module according to the following procedure. (The retard roller module is located in the conveyor.)

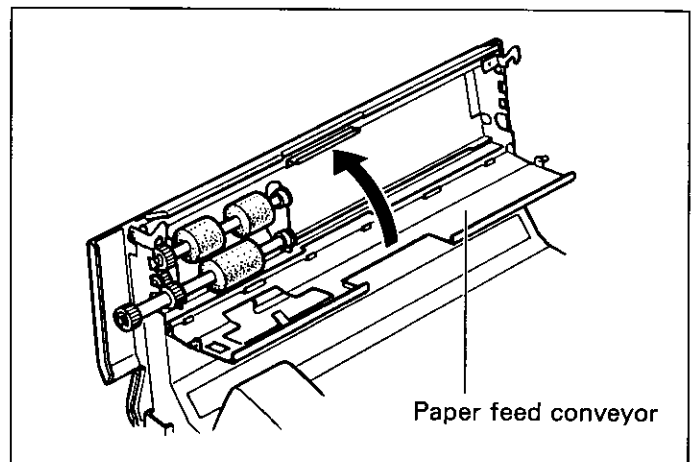

- 10** Using your fingers, hold the conveyor and pull it towards you to open it.

- When the conveyor is pulled towards you, the click-stop mechanism will be released.

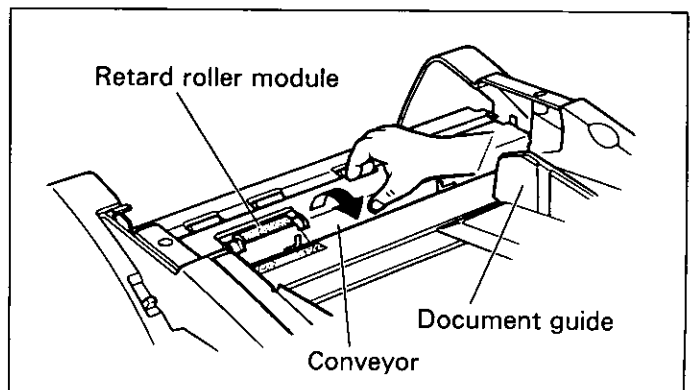

Replacing Consumable Roller Modules

- 11** Pull the right side of the shaft in the direction of arrow ①, and hold it there.
Pull the retard roller module in the direction of arrow ②, and then remove it.

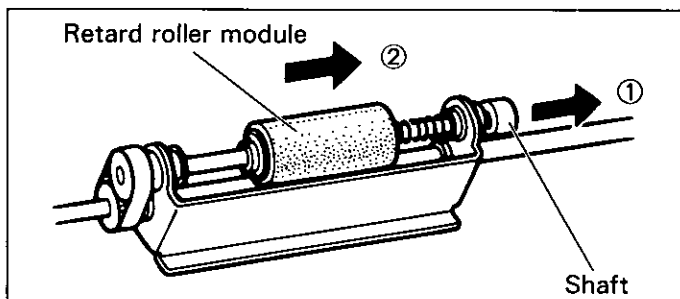

- 12** Take out the retard roller module in the optional "Roller Exchange Kit (KV-SS044)".
For supplies and accessories:
Call 1-800-346-4768 (U. S. A. only)
or your dealer.

- 13** Pull the right side of the shaft in the direction of arrow ① and hold it there.
Attach the new retard roller module as shown in the direction of arrow ②.
Return the right side of the shaft as shown in the direction of arrow ③.

- Confirm if pin A and pin B are inserted in their notches correctly.
- Attach the retard roller module so that the notch A is on the left side.

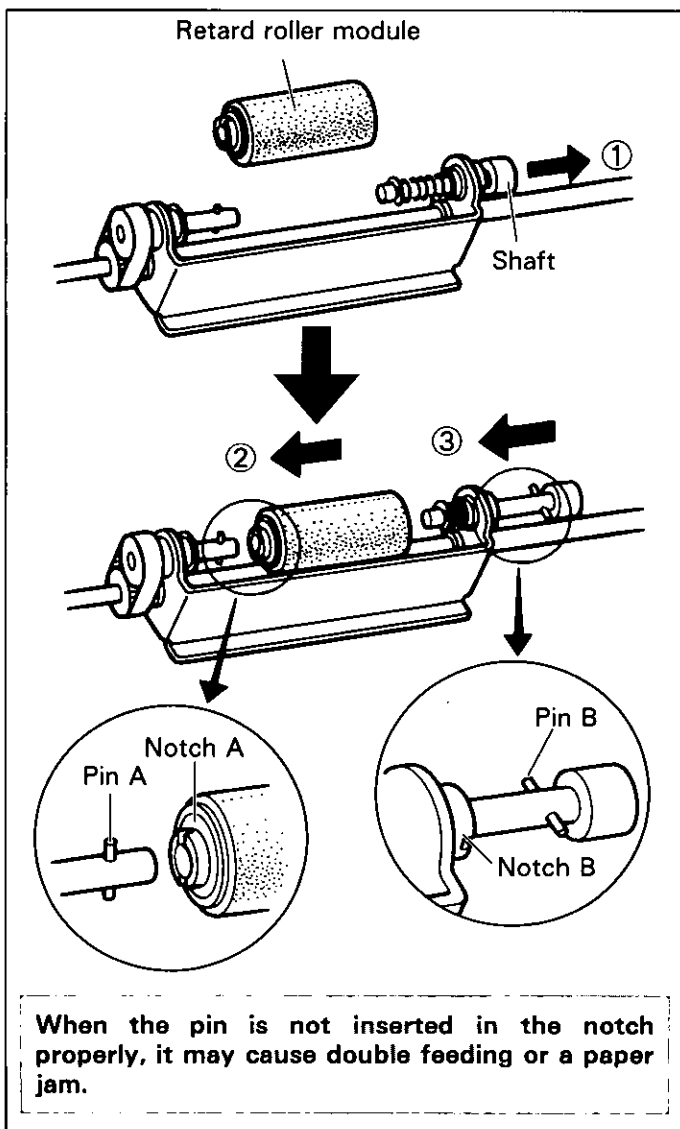

14 Close the conveyor by pushing it into the unit.

- When the conveyor is closed, the click-stop mechanism will operate.
- If the conveyor is not closed correctly and the operation in step 15 is done, the conveyor may break.

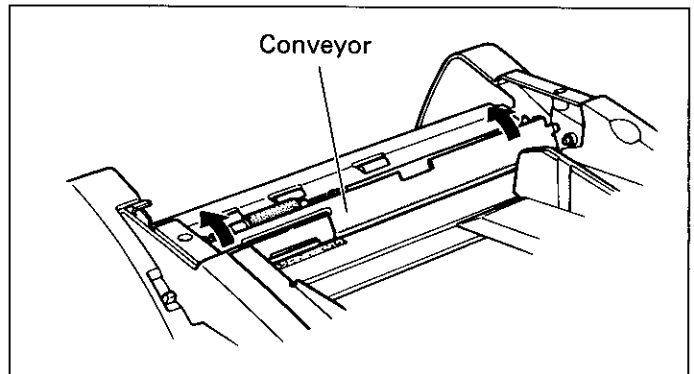

15 Close the ADF door.

- Push both sides of the ADF door down gently until it clicks into place.
- Since the rollers are located on the left side of the ADF door, there is more weight on the left side. Therefore, it is important to note that the door needs to have tension evenly divided to close it properly.
- After replacing roller modules, clear the "Replace Roll. Warning" display. (Refer to page 22.)

Before closing the ADF door, confirm that the conveyor is closed correctly. If it is not, the conveyor may break.

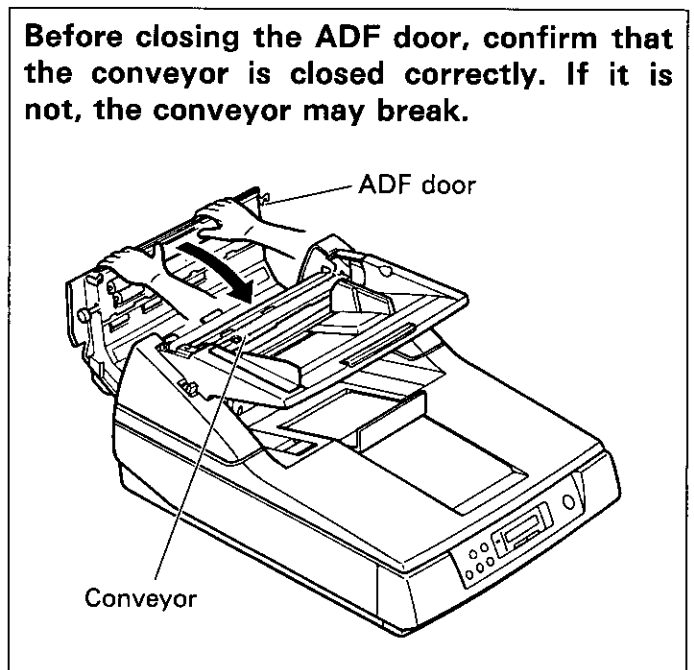

Repacking Instructions

It is highly recommended that you keep the original carton and ALL packing materials. If you need to transport or ship your scanner, please follow these instructions.

Please Note :

- Please use the original carton and all of the original packing materials. If you do not have the original packing materials, these are available from your Panasonic dealer. Please refer to your service dealer, or call 1-800-833-9626 (U. S. A. only) or your dealer.
- **Improper repacking of the scanner may result in a service charge to repair the unit.**
- The scanner should be handled in the correct (horizontal) position.

Materials Required :

- Original Scanner Carton & Packing Materials
- Shipping Tape and Scissors

1 Disconnect your scanner from the electrical outlet and the interface cable.

2 Remove the SCSI interface board.
● Please refer to "Installation Instructions for the SCSI Interface Board and SIMM Module" enclosed with the unit.

3 Fix the optical unit of the flatbed and attach the protective sheets with tapes.
● Please refer to the installation manual enclosed with the unit.
● Turn the power on and complete initializing (return the optical unit to the original position), then attach the metal clamp at position (A). (Refer to page 3 on the installation manual.)

4 Pack the scanner.

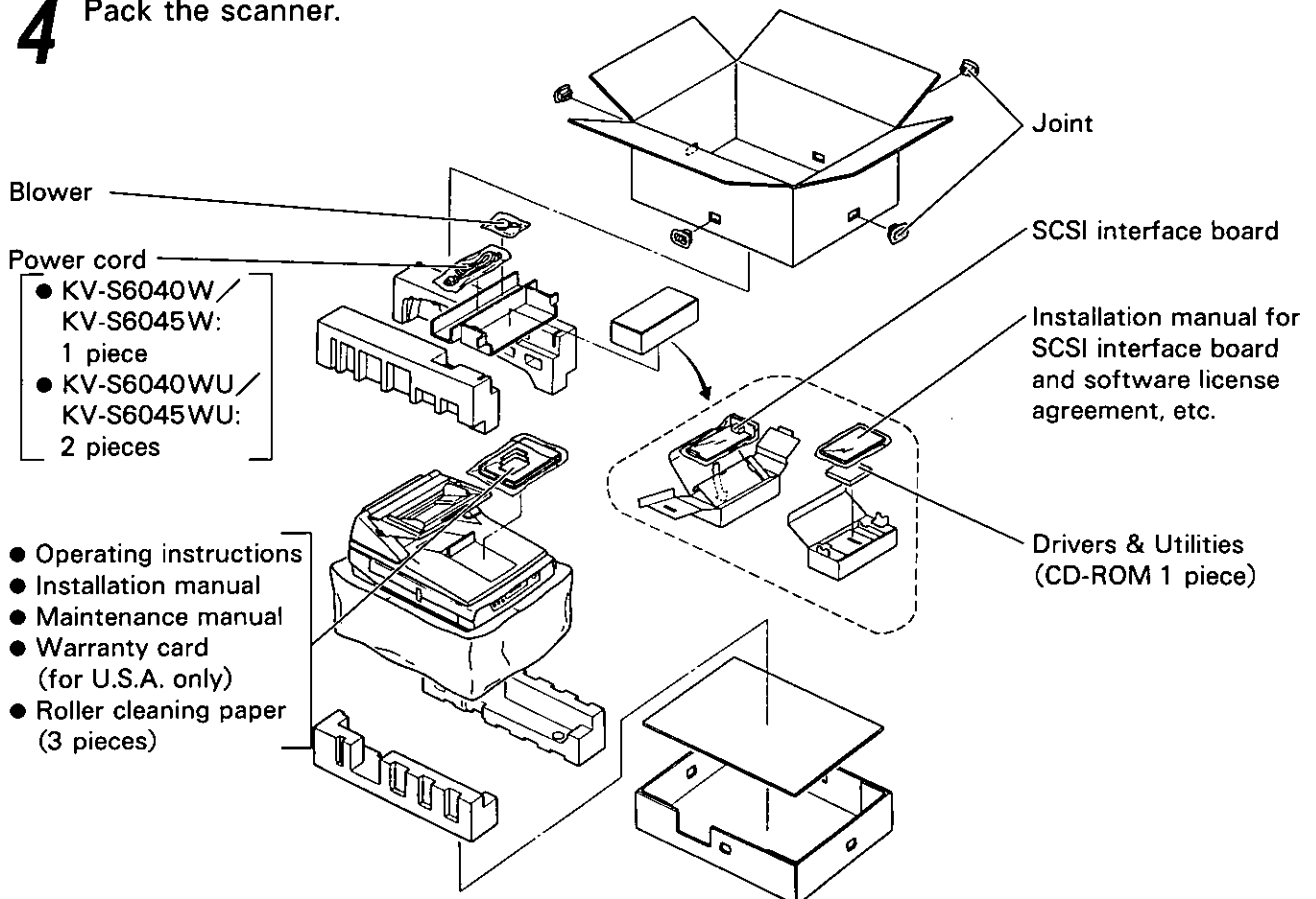

Specifications

Item		Model No.	KV-S6040W	KV-S6045W
Scanner	Scanning face		Simplex scanning	Duplex scanning
	Scanning method		CCD image sensor	ADF front side/Flatbed : CCD image sensor ADF back side : CIS (Contact Type Image Sensor)
	Readout speed	Flatbed	1.5 sec (1 paper, letter size, 200 dpi)	
		ADF	Simplex scanning : Approx. 45 sheets/min. (Letter, fed lengthwise, 200 dpi) Duplex scanning : Approx. 41 sheets/min. (KV-S6045W only) (Letter, fed lengthwise, 200 dpi)	
	Resolution	Flatbed/ ADF	Main scanning direction : 100 ~ 600dpi (1 dpi step) Sub-scanning direction : 100 ~ 600dpi (1 dpi step) The optical resolution is 400 dpi.	
	Tonal gradation		Binary mode, Grayscale mode (2/4/8 bit), 64-step gradation (dither) mode, 64-step gradation (error diffusion) mode	
	Image control		Image emphasis, Automatic threshold, Automatic separation, Monochrome reversing, Automatic back control	
	Paper	Size for Flatbed	~298×432 mm (11.7×17 in.)	
		Size for ADF	Scanning size : 70×169mm (2.8×6.7 in.), and 106×148mm (4.2×5.8 in.) to 298×432mm (11.7×17 in.) Feeding size : 70×169mm (2.8×6.7 in.), and 106×148mm (4.2×5.8 in.) to 305×432mm (12×17 in.)	
		Thickness for ADF	Single paper feeding : 0.05 to 0.15mm (2.0 to 5.9 mils) Continuous paper feeding : 0.06 to 0.15mm (2.4 to 5.9 mils) Note : 1 mil=1/1000 in.	
Weight for ADF		Single paper feeding : 40 to 127 g/m ² (10.6 to 34 lbs.) Continuous paper feeding : 50 to 127 g/m ² (13 to 34 lbs.)		
Hopper capacity		200 sheets [64 g/m ² (17 lbs.), un used paper]		
Unit	External dimensions (Width×Depth×Height)		464×717×296mm (18.3×28.2×11.7 in.)	
	Mass (Weight)		30kg (66 lbs.)	
	Power requirement		AC100 - 120V, 50/60Hz	
	Power consumption	Maximum (Scanning)	1.8A	
Minimum (Standby)		0.5A		
Operating Environment	Operating temperature and humidity		15°C to 30°C (59°F to 86°F), 30% to 80%RH	
Storage Environment	Storage temperature and humidity		0°C to 35°C (32°F to 95°F), 10% to 80%RH	
Option	Roller exchange kit (KV-SS044), Imprinter unit (KV-SS010), Red lamp option (KV-SS045), Roller cleaning paper (KV-SS03), Ink cartridge (KV-SS06)			

- "Weight in pounds" of paper represents the weight of 500 [432×559mm (17×22 inches)] sheets.
- The red lamp option (KV-SS045) must be installed by a trained service engineer. Consult your dealer.
- If the red lamp is installed, any red letters on the back side of the document will automatically not be scanned.

Specifications

Item		Model No.	KV-S6040WU	KV-S6045WU	
Scanner	Scanning face		Simplex scanning	Duplex scanning	
	Scanning method		CCD image sensor	ADF front side/Flatbed : CCD image sensor ADF back side : CIS (Contact Type Image Sensor)	
	Readout speed	Flatbed		1.5 sec (1 paper, letter size, 200 dpi)	
		ADF		Simplex scanning : Approx. 45 sheets/min. (Letter, fed lengthwise, 200 dpi) Duplex scanning : Approx. 41 sheets/min. (KV-S6045WU only) (Letter, fed lengthwise, 200 dpi)	
	Resolution	Flatbed/ ADF	Main scanning direction : 100 ~ 600dpi (1 dpi step) Sub-scanning direction : 100 ~ 600dpi (1 dpi step) The optical resolution is 400 dpi.		
	Tonal gradation		Binary mode, Grayscale mode (2/4/8 bit), 64-step gradation (dither) mode, 64-step gradation (error diffusion) mode		
	Image control		Image emphasis, Automatic threshold, Automatic separation, Monochrome reversing, Automatic back control		
	Paper	Size for Flatbed		~298 × 432 mm	
		Size for ADF		Scanning size : 70 × 169mm, and 106 × 148mm to 298 × 432mm Feeding size : 70 × 169mm, and 106 × 148mm to 305 × 432mm	
		Thickness for ADF		Single paper feeding : 0.05 to 0.15mm Continuous paper feeding : 0.06 to 0.15mm	
Weight for ADF			Single paper feeding : 40 to 127 g/m ² Continuous paper feeding : 50 to 127 g/m ²		
Hopper capacity		200 sheets (64 g/m ² , un used paper)			
Unit	External dimensions (Width × Depth × Height)		464 × 717 × 296mm		
	Mass (Weight)		30kg		
	Power requirement		AC220 - 240V, 50/60Hz		
	Power consumption	Maximum (Scanning)		1.0A	
Minimum (Standby)			0.3A		
Operating Environment	Operating temperature and humidity		15°C to 30°C, 30% to 80%RH		
Storage Environment	Storage temperature and humidity		0°C to 35°C, 10% to 80%RH		
Option	Roller exchange kit (KV-SS044), Imprinter unit (KV-SS010), Red lamp option (KV-SS045), Roller cleaning paper (KV-SS03), Ink cartridge (KV-SS06)				

- The red lamp option (KV-SS045) must be installed by a trained service engineer. Consult your dealer.
- If the red lamp is installed, any red letters on the back side of the document will automatically not be scanned.

Troubleshooting

If a problem occurs while the unit is being used, first check the following items. If the unit still malfunctions, turn it OFF, unplug the power cord and call for service.

Symptom	Possible Cause	Remedy
The LCD does not display when the power switch is turned ON.	The power cord is not plugged in.	Insert the power plug firmly.
	A fuse has blown.	Pull out the power plug, then call for service.
	Foreign matter is lodged in the fan, preventing it from rotating.	
The scanner rattels during initialization after turning on, and the LCD displays "F41 Call Service".	The optical unit of flatbed remains affixed by the metal clamp.	Remove the metal clamp and re-attach it at the proper position (position B). (Refer to "Installation" on the Installation Manual.)
Double feeding problem occurs.	The rollers are dirty.	Clean all of the rollers. (See pages 34 through 37.)
The document stops during scanning in the ADF.	The document is creased or torn, or longer than A3 size or smaller than 106×148 mm (4.2×5.8 in.).	Make a copy of the document on paper of the specified size [between 106×148 mm (4.2×5.8 in.) and A3 size] and scan the copy.
	The document is jammed.	Refer to the next page. (See pages 52 and 53.)
The document is not fed smoothly into the ADF during scanning.	The rollers are dirty.	Clean all of the rollers. (See pages 34 through 37.)
	Paper feed rollers, separation roller and retard roller are the end of their life.	Replace paper feed roller module, separation roller module and retard roller module. (See pages 42 through 47.)
The scanned document is blank.	The document to be scanned was loaded face down (upside down).	Load the document correctly.
	The scanning conditions are set on the computer side but the scanner condition setting for each item have not become "Host".	Return all of the scanning conditions for each item's setting to "Host".
The scanned document is skewed.	The document guides were not touching the edges of the document, or the document was skewed when loaded.	Set the document guides or the document correctly.
Vertical lines appear on the scanned document.	The white sensor roller, scanning section glass or the rubber rollers are dirty.	Wipe the dirty parts with a clean cloth. (See pages 37 through 40.)
The scanned document is faint.	The white sensor roller is dirty.	Clean the white sensor roller. (See pages 37 through 40.)
The computer does not recognize the scanner.	The computer cannot recognize the scanner.	Turn the computer OFF. Turn the scanner ON, and then turn the computer ON again.
		Confirm the SCSI ID and product ID, and then set them correctly.
The double feed detection sensor is not operating.	There is dust from the paper on the double feed detection sensor.	Please clean the double feed detection sensor with the included blower. (See page 38.)
	The double feed detector sensitivity setting does not match the scanning document.	Change the double feed detector sensitivity setting. (See page 23.)
Black dots or white patches occur when scanning with flatbed.	The document glass and cover sheet are dirty.	Clean the document glass and cover sheet. (See page 41.)

Troubleshooting

LCD	Possible Cause	Remedy
<p>***Warning*** Clean Roller</p> <p>***Achtung*** Walzenreiniigen</p>	The rollers are dirty.	Clean the rollers. (See pages 34 through 37.)
<p>***Warning*** Replace Roller</p> <p>***Achtung*** Walzen tauschen</p>	The rollers need to be replaced.	Replace the paper feed roller module, separation roller module and retard roller module. (See pages 42 through 47.)
<p>***Warning*** Double Feed Occurred</p> <p>***Achtung*** Doppell-Einzug</p>	Double feed may have occurred.	Check the scanned data.
<p>U11 JAM</p> <p>U11 Staub</p>	The document is jammed.	Open the front or ADF door and remove the jammed paper. (See pages 32 and 33.)
<p>U12 JAM</p> <p>U14 JAM</p> <p>U16 JAM</p> <p>U12 Staub</p>	Dust adheres to the paper detection sensor.	Clean a dust using the included blower. (See page 38.)
<p>U12 JAM</p> <p>U14 JAM</p> <p>U16 JAM</p> <p>U12 Staub</p>	The document is jammed or the document has been feeded obliquely.	Open the front or ADF door and remove the jammed paper. (See pages 32 and 33.)
<p>U18 Remaind Doc.</p> <p>U18 Verbl. Dok.</p>	A document remains in the scanner.	Open the front or ADF door and remove all of the remaining documents.
<p>U18 Verbl. Dok.</p>	Dust adheres to the document sensors.	Clean a dust using the included blower. (See pages 38 and 39.)
<p>U20 Skew Error</p> <p>U20 Schrägeinzug</p>	A document has been feeded obliquely.	Open the ADF door and remove the paper.
<p>U23 Double Feed</p> <p>U23 Doppelleinzug</p>	Multiple sheets were fed into the unit.	Open the front or ADF door and remove the jammed paper. (See pages 32 and 33.)

* Upper display in each cell is in English and lower one is in German.

LCD	Possible Cause	Remedy																																																																								
<table border="1" style="width: 100%; border-collapse: collapse;"> <tr><td>U30</td><td>F</td><td>r</td><td>o</td><td>n</td><td>t</td><td>D</td><td>o</td><td>o</td><td>r</td><td></td><td></td></tr> <tr><td></td><td></td><td></td><td></td><td></td><td></td><td>X</td><td>X</td><td>X</td><td>X</td><td>X</td><td>X</td></tr> </table> <table border="1" style="width: 100%; border-collapse: collapse;"> <tr><td>U30</td><td>F</td><td>r</td><td>o</td><td>n</td><td>t</td><td>K</td><td>l</td><td>a</td><td>p</td><td>p</td><td>e</td></tr> <tr><td></td><td></td><td></td><td></td><td></td><td></td><td>X</td><td>X</td><td>X</td><td>X</td><td>X</td><td>X</td></tr> </table>	U30	F	r	o	n	t	D	o	o	r									X	X	X	X	X	X	U30	F	r	o	n	t	K	l	a	p	p	e							X	X	X	X	X	X	The front door is open.	Close the front door.																								
U30	F	r	o	n	t	D	o	o	r																																																																	
						X	X	X	X	X	X																																																															
U30	F	r	o	n	t	K	l	a	p	p	e																																																															
						X	X	X	X	X	X																																																															
<table border="1" style="width: 100%; border-collapse: collapse;"> <tr><td>U31</td><td>A</td><td>D</td><td>F</td><td>D</td><td>o</td><td>o</td><td>r</td><td></td><td></td><td></td><td></td></tr> <tr><td></td><td></td><td></td><td></td><td></td><td></td><td>X</td><td>X</td><td>X</td><td>X</td><td>X</td><td>X</td></tr> </table> <table border="1" style="width: 100%; border-collapse: collapse;"> <tr><td>U31</td><td>A</td><td>D</td><td>F</td><td>T</td><td>ü</td><td>r</td><td>o</td><td>f</td><td>n</td><td></td><td></td></tr> <tr><td></td><td></td><td></td><td></td><td></td><td></td><td>X</td><td>X</td><td>X</td><td>X</td><td>X</td><td>X</td></tr> </table>	U31	A	D	F	D	o	o	r											X	X	X	X	X	X	U31	A	D	F	T	ü	r	o	f	n									X	X	X	X	X	X	The ADF door is open.	Close the ADF door.																								
U31	A	D	F	D	o	o	r																																																																			
						X	X	X	X	X	X																																																															
U31	A	D	F	T	ü	r	o	f	n																																																																	
						X	X	X	X	X	X																																																															
<table border="1" style="width: 100%; border-collapse: collapse;"> <tr><td>U34</td><td>T</td><td>o</td><td>p</td><td>D</td><td>o</td><td>o</td><td>r</td><td></td><td></td><td></td><td></td></tr> <tr><td></td><td></td><td></td><td></td><td></td><td></td><td>X</td><td>X</td><td>X</td><td>X</td><td>X</td><td>X</td></tr> </table> <table border="1" style="width: 100%; border-collapse: collapse;"> <tr><td>U34</td><td>O</td><td>b</td><td>e</td><td>r</td><td>e</td><td>K</td><td>l</td><td>a</td><td>p</td><td>p</td><td>e</td></tr> <tr><td></td><td></td><td></td><td></td><td></td><td></td><td>X</td><td>X</td><td>X</td><td>X</td><td>X</td><td>X</td></tr> </table>	U34	T	o	p	D	o	o	r											X	X	X	X	X	X	U34	O	b	e	r	e	K	l	a	p	p	e							X	X	X	X	X	X	The imprinter (top) door is open.	Close the imprinter door.																								
U34	T	o	p	D	o	o	r																																																																			
						X	X	X	X	X	X																																																															
U34	O	b	e	r	e	K	l	a	p	p	e																																																															
						X	X	X	X	X	X																																																															
<table border="1" style="width: 100%; border-collapse: collapse;"> <tr><td>U35</td><td>D</td><td>o</td><td>c</td><td>.</td><td>C</td><td>o</td><td>v</td><td>e</td><td>r</td><td></td><td></td></tr> <tr><td></td><td></td><td></td><td></td><td></td><td></td><td>X</td><td>X</td><td>X</td><td>X</td><td>X</td><td>X</td></tr> </table> <table border="1" style="width: 100%; border-collapse: collapse;"> <tr><td>U35</td><td>D</td><td>o</td><td>k</td><td>.</td><td>A</td><td>b</td><td>d</td><td>e</td><td>c</td><td>k</td><td></td></tr> <tr><td></td><td></td><td></td><td></td><td></td><td></td><td>X</td><td>X</td><td>X</td><td>X</td><td>X</td><td>X</td></tr> </table>	U35	D	o	c	.	C	o	v	e	r									X	X	X	X	X	X	U35	D	o	k	.	A	b	d	e	c	k								X	X	X	X	X	X	The document cover is open.	Close the document cover.																								
U35	D	o	c	.	C	o	v	e	r																																																																	
						X	X	X	X	X	X																																																															
U35	D	o	k	.	A	b	d	e	c	k																																																																
						X	X	X	X	X	X																																																															
<table border="1" style="width: 100%; border-collapse: collapse;"> <tr><td>HXX</td><td>C</td><td>a</td><td>l</td><td>S</td><td>e</td><td>r</td><td>v</td><td>i</td><td>c</td><td>e</td><td></td></tr> <tr><td></td><td></td><td></td><td></td><td></td><td></td><td>X</td><td>X</td><td>X</td><td>X</td><td>X</td><td>X</td></tr> </table> <table border="1" style="width: 100%; border-collapse: collapse;"> <tr><td>FXX</td><td>C</td><td>a</td><td>l</td><td>S</td><td>e</td><td>r</td><td>v</td><td>i</td><td>c</td><td>e</td><td></td></tr> <tr><td></td><td></td><td></td><td></td><td></td><td></td><td>X</td><td>X</td><td>X</td><td>X</td><td>X</td><td>X</td></tr> </table> <table border="1" style="width: 100%; border-collapse: collapse;"> <tr><td>HXX</td><td>S</td><td>e</td><td>r</td><td>v</td><td>.</td><td>r</td><td>u</td><td>f</td><td>e</td><td>n</td><td></td></tr> <tr><td></td><td></td><td></td><td></td><td></td><td></td><td>X</td><td>X</td><td>X</td><td>X</td><td>X</td><td>X</td></tr> </table>	HXX	C	a	l	S	e	r	v	i	c	e								X	X	X	X	X	X	FXX	C	a	l	S	e	r	v	i	c	e								X	X	X	X	X	X	HXX	S	e	r	v	.	r	u	f	e	n								X	X	X	X	X	X	A user non-servicable error has occurred.	Please consult with a service representative.
HXX	C	a	l	S	e	r	v	i	c	e																																																																
						X	X	X	X	X	X																																																															
FXX	C	a	l	S	e	r	v	i	c	e																																																																
						X	X	X	X	X	X																																																															
HXX	S	e	r	v	.	r	u	f	e	n																																																																
						X	X	X	X	X	X																																																															
<table border="1" style="width: 100%; border-collapse: collapse;"> <tr><td>U50</td><td>N</td><td>o</td><td>/</td><td>F</td><td>B</td><td>o</td><td>a</td><td>r</td><td>d</td><td></td><td></td></tr> <tr><td></td><td></td><td></td><td></td><td></td><td></td><td>X</td><td>X</td><td>X</td><td>X</td><td>X</td><td>X</td></tr> </table> <table border="1" style="width: 100%; border-collapse: collapse;"> <tr><td>U50</td><td>K</td><td>.</td><td>S</td><td>c</td><td>h</td><td>n</td><td>i</td><td>t</td><td>t</td><td>s</td><td>t</td></tr> <tr><td></td><td></td><td></td><td></td><td></td><td></td><td>X</td><td>X</td><td>X</td><td>X</td><td>X</td><td>X</td></tr> </table>	U50	N	o	/	F	B	o	a	r	d									X	X	X	X	X	X	U50	K	.	S	c	h	n	i	t	t	s	t							X	X	X	X	X	X	An interface board has not been installed.	Install the optional interface board.																								
U50	N	o	/	F	B	o	a	r	d																																																																	
						X	X	X	X	X	X																																																															
U50	K	.	S	c	h	n	i	t	t	s	t																																																															
						X	X	X	X	X	X																																																															

Index

	Page		Page
A			
AC inlet	9	Error diffusion	16, 17
ADF door	9, 32	Exit document stopper	9, 26
ADF door release	9, 32	F	
B			
Back side brightness	12, 16	Fan exhaust vent	9, 34
Back side contrast	12, 16	Fill indicator	26, 27
Back side halftone	12, 17	Front door release	9, 29
Back side image emphasis	12, 16	Front side brightness	12, 15
Bayer dither 16	16, 17	Front side contrast	12, 15
Bayer dither 64	16, 17	Front side halftone	12, 16
Binary	16, 17	Front side image emphasis	12, 15
Black line removal	12, 17	H	
C			
Carbon or carbonless paper	27	Halftone dot 32	16, 17
Checking the Firmware Version	13, 21	Halftone dot 64	16, 17
Checking the "Roller Cleaning Warning"	13, 22	High	16
Checking the roller modules		HOME	11, 14
replacement warning	13, 22	Hopper	9, 26
CIS glass	10, 37	Hopper extension tray	9, 27
Clearing the "Roller Cleaning Warning"	13, 22	Host	15, 16
Clearing the roller modules		I	
replacement warning	13, 22	IMPRINT	11, 14
Clear the "User Counter"	12, 19	Imprinter door	9
Connector	9	Imprinter setting menu	20
Conveyor	45	L	
COUNTER	11, 14	Landscape	26
Counter setting menu	19	LCD (Liquid Crystal Display)	11
Cover sheet	10, 41	Load scanning setting	12, 18
D			
Default	12, 18	Low	16
Detect	17		
Display panel	9, 11		
Document glass	10, 41		
Document guide	9, 26		
Document sensor	34, 37		
Double feed detection	12, 17		

	Page
M	
Manual feed selector	9, 31
Medium	15, 16
Menu	11, 14
N	
Noise reduction	12, 17
None	15, 16
Norm	15, 16
Normal	17
Not detect	17
O	
Operating environment	49, 50
P	
Paper detection sensor	37, 38
Paper feed conveyor	42
Paper feed roller module	43
Portrait	26
Power consumption	49, 50
Power cord	9
Power requirement	49, 50
Power switch	9, 34
R	
Readout speed	49, 50
Retard roller module	46
Roller cleaning paper	36, 41
S	
Save "Scanning Settings"	12, 18
SCAN	11, 14
Scanning face	49, 50
Scanning method	12, 18
Scanning section glass	10, 37
Select the counter displayed on the LCD	12, 19
Separation roller module	43
Setting the "Buzzer"	13, 21

	Page
Setting the imprinter data	13, 20
Setting the imprinter position	13, 20
Setting the language	24
Setting the "Product ID"	13, 23
Setting the SCSI ID	13, 21
Setting the "Terminator"	13, 21
Setting the user counter	12, 19
Setting the "User Counter Extender"	12, 19
Smooth	15, 16
Standard mark	10, 28
U	
User counter	19
W	
White plate	34, 37
White sensor roller	34, 37

Panasonic Document Imaging Company
A Division of Matsushita Electric Corporation of America
Two Panasonic Way, Secaucus, New Jersey 07094

Panasonic Canada Inc.
5770 Ambler Drive, Mississauga, Ontario, L4W 2T3

Matsushita Electric Industrial Co., Ltd.
Central P. O BOX 288, Osaka 530-91, Japan

Printed in Japan



PBQX50233WA K0199E5119